



PACKMAN
Industrial Group

Last update: 27/11/2022

II or III Stages Mono-Block Gas or Dual-Fuel Burner From 100 kW up to 6200 kW

www.packmangroup.com
www.raadmanburner.com

- raadman -
A look to the future





A LOOK TO THE FUTURE

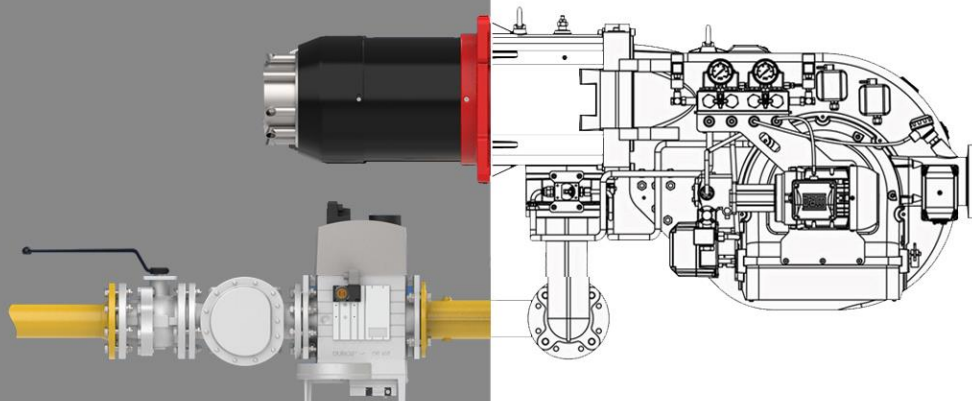

More than
48 Years of Reliability



History

The PACKMAN Company was established in February of 1975. This company started its official activity in the field of construction of High-Pressure Vessels such as Hot-Water Boilers, Steam Boilers, Pool Coil Tanks, Softeners and Heat Exchangers from 1984. As the first supplier of Hot water boilers with high quality and standard mark, PACKMAN has started exporting its products to countries such as Uzbekistan, United Arab Emirates and other countries in the region. Currently, PACKMAN honor-fully is one of the largest producers of hot-water and steam boilers in the Middle East. After 40 years of experience in the field of heating industry, especially boilers and burners, this group started his activity on January 2011 in the area of burners with brand of raadman. The main objective of this group was improvement and development of industrial burners in order to produce high quality and highly efficient industrial burners with optimum operation in the Middle East. Based on technical knowledge and engineering design of industrial burners, PACKMAN Corporation started the production of low, medium and big sized industrial burners. By the efforts of engineers of R&D department, the burner's combustion improved significantly and as a consequence, the production of burners developed rapidly. Gas, Light oil (LFO), Heavy oil (HFO) and dual/triple fuel burners with different firing ranges were produced and tested successfully.

Nowadays, the burners of this company cover a firing range of 100 to 60000 kW. Single stage, double stage, modular and Low NOx burners (generally lower than 80 mg/kWh and individually lower than 40 mg/kWh) are available for various domestic and industrial applications. High quality, optimum operation and customer satisfaction has always been considered in the production of raadman burners. Diversity and high quality of raadman burners, besides their easy installation and maintenance make them a perfect selection for many customers.



R LG B- * - 255 / LN

Blank: NOx class: II acc to EN-676

LN: Low NOx with Class III acc to EN-676

Reference of approximate Capacity x 10 kW

Operation:
Blank: Two Stage or One Stage
M: Natural Gas, LPG: Electronic Modular
Light Oil, Heavy Oil: Two/Three Stage Progressive
M/M: Natural Gas, LPG: Electronic Modular
Light Oil, Heavy Oil: Electronic Modular

B: Burner

Type of Fuel
G: G=Natural gas
GP: G=Natural gas, P=Propane
LG: L=Light oil, G=Natural gas
LGP: L=Light oil, G=Natural gas, P=Propane
LHG: L=Light oil, H=Heavy oil, G=Natural gas
LHGP: L=Light oil, H=Heavy oil, G=Natural gas, P=Propane

Product Family Name: RAADMAN



Firing ranges

Gas burners (RGB Series):

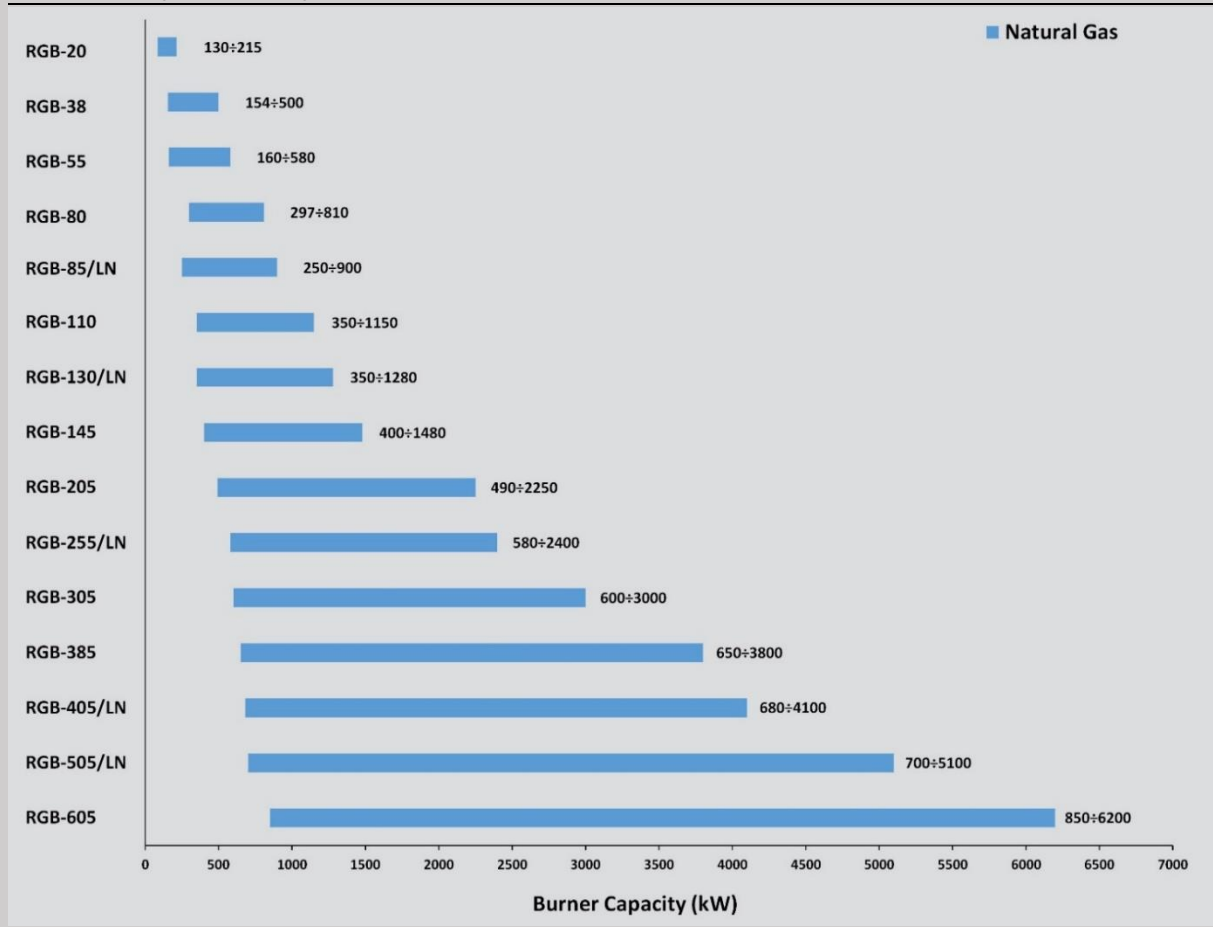

Dual Fuel burners (RLGB Series):

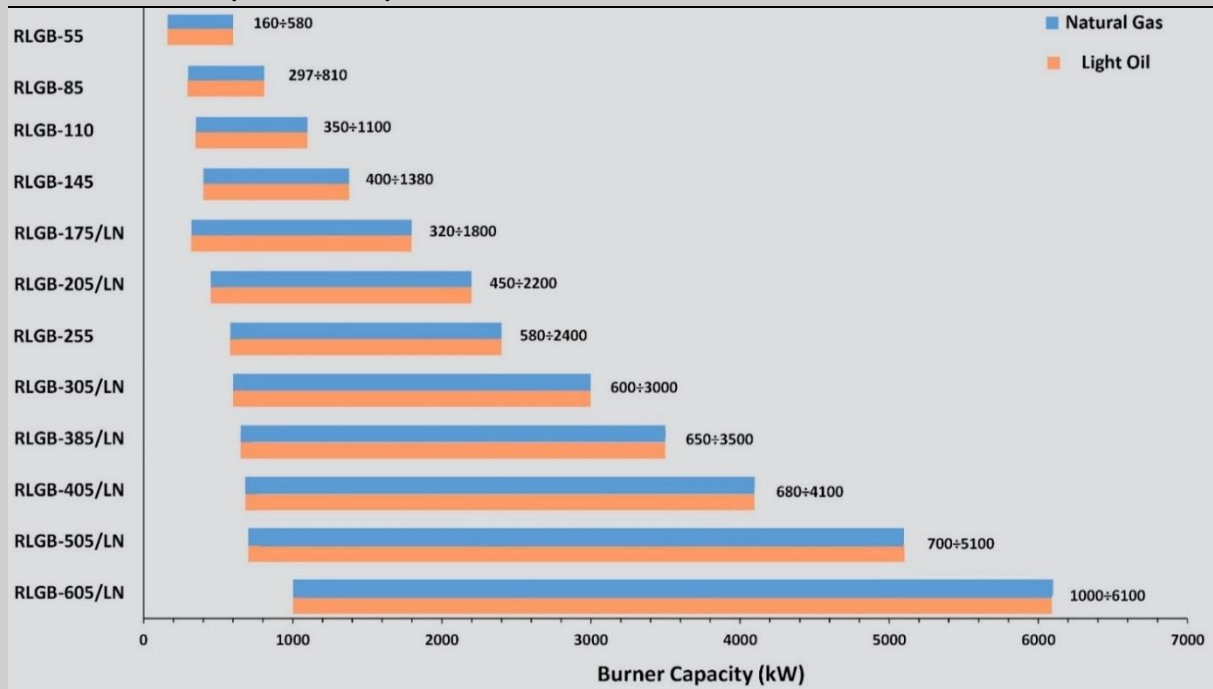

Staging mono block raadman burner

raadman Staging burners cover a firing range from 160 kW to 6200 kW in II or III stage Natural gas and light fuel oil. These burners, with high-quality electro/mechanical accessories with easy installation, commissioning and maintenance, are economically designed for city or industrial applications such as three pass hot water boilers, steam boilers, hot air generator etc.

Two or three stage burners, following the temperature/steam load requested by the system, allow operating at full (or medium) and reduced output, with consequent reduction in turning the burner on and off, that gives better performances to the boiler. Since the burner's air damper is independently controlled by an electric servomotor, during stand-by, the air entrances are getting completely closed and prevents heat loss due to the flue natural draught.

One of the most highlighted privileges of Raadman-Staging, is the lack of mechanical link between gas butterfly valve and air damper. In other word, air damper is controlled with an independent two or three stepping actuators. At the same time, gas (or light oil) is controlled with two or three parallel solenoid valves, resulting an ability of precise control and adjustment on each of burner stages. This helps a superior and complete combustion.

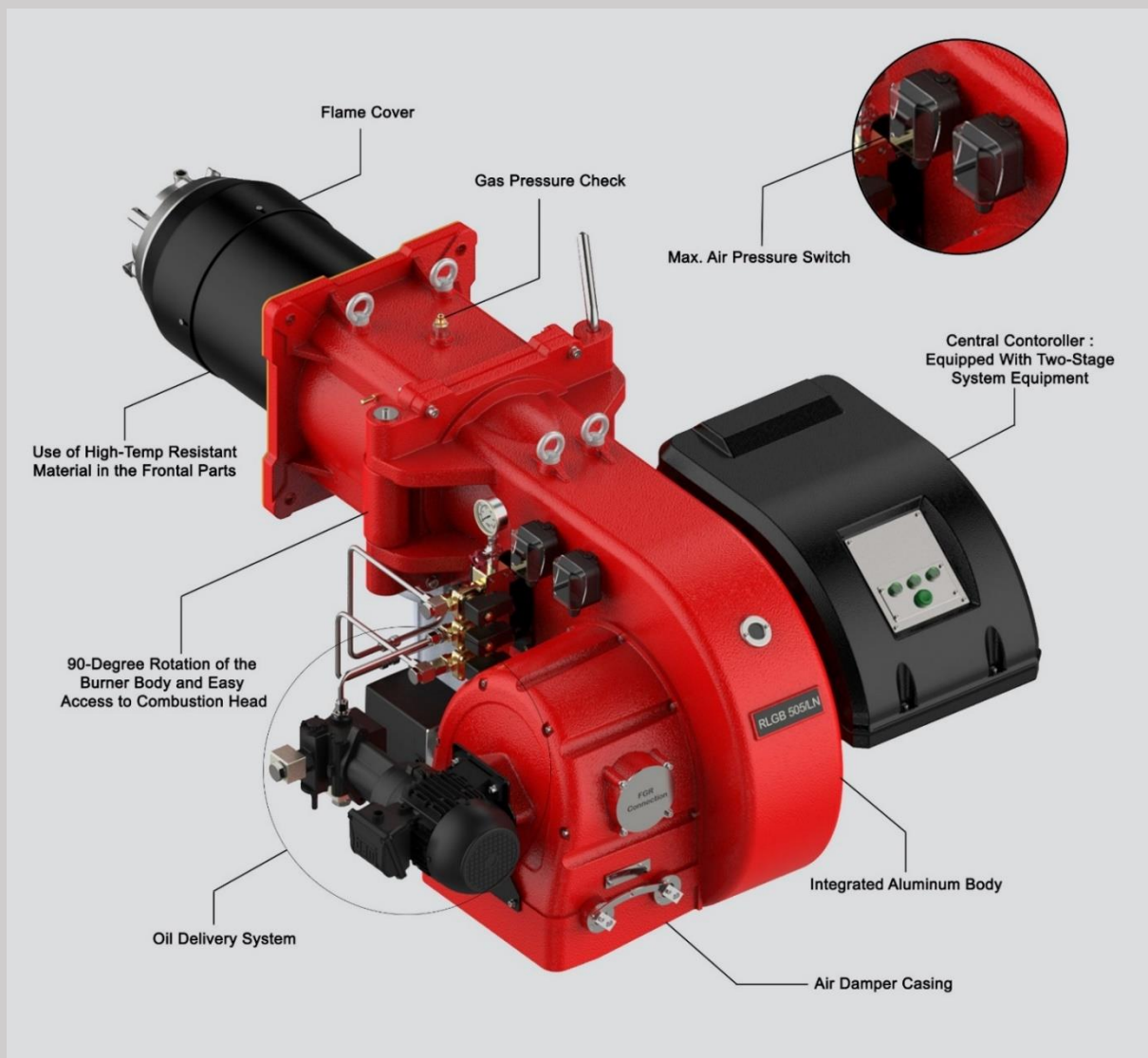

CFD experts in R&D department

Industry relies on heat from the burners in all combustion systems. Optimizing burner performance is critical to complying with stringent emissions requirements and to improve industrial productivity. Engineers involved in designing and building advanced combustion equipment for the hydrocarbon process industries routinely use Advanced CFD to advance new burner technology. The science and technology of CFD has matured to the point where performance predictions are made with a degree of confidence from models covering a wide range of complex furnace, burner, and reactor geometries.

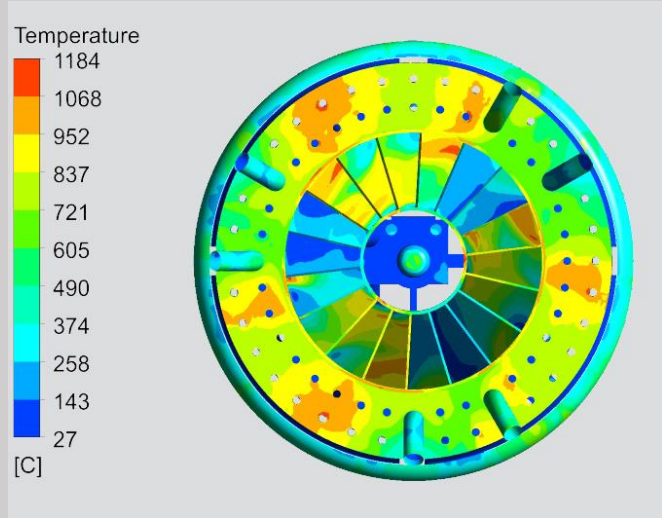

While tremendous advances have been made in understanding the fundamentals of combustion, the remaining challenges are complex. To make improvements, it is critical to understand the dynamics of the fuel fluid flow and the flame and its characteristics. Computational Fluid Dynamics offers a numerical modeling methodology that helps in this regard. Commercial CFD codes utilize a standard approach to simulate chemical kinetics, which approximate the consumption and production of chemical species. This causes the engineer to use simplifying assumptions about the chemistry considered in the simulation. CFD can help engineers to optimize flow through orifices, blades and swirlers to achieve a homogenous mixture of air and gas.

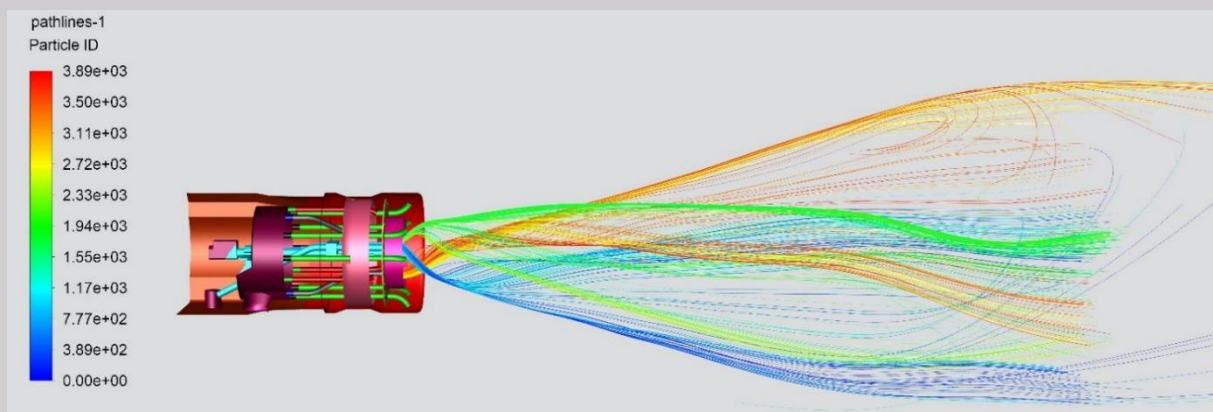
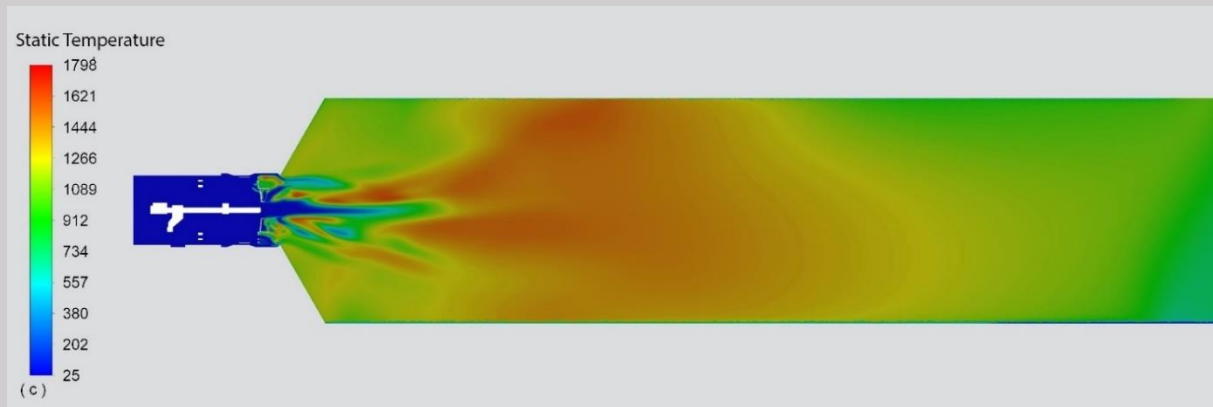

Specification



Fuels

- Natural gas
- Light oil (viscosity < 6 cSt)
- Other types of fuels (such as heavy oil, LPG etc.) requires written confirmation from burner department of packman corporation (raadman brand).

Applications

Raadman gas and dual fuel burners are suitable for the following utilizations.

- Installation on heat exchanger
- Hot water boiler
- Steam boiler and high-pressure hot water boiler
- Hot air generator
- Compatible with all types of combustion chambers according to EN303 standard.

Technical & Functional Features

Light weight and optimized geometry.

High quality heat resistant steel material for the all parts of burner head as well as flame covering accessories.

Mono-bloc design and fully enclosed aluminum air housing. Simple Installation, adjustment and maintenance.

Easy access to internal components.

Engineered for maximize efficiency and fuel cost savings.

Suitable for firetube, firebox and water tube boilers

Equipped with high quality and reliable electronic devices.

Up to 10-20 % flame shape control

High quality staging controllers from well-known producers.

Standard compliance

Designed in accordance with ISIRI-7595 and ISIRI-7594 Iran national standard (equal to the BS-EN676, BS-EN267 European standards)

Control

The following methods of regulation are available for Raadman-Staging (Mono-Bloc) burners:

Gas/oil: Two or Three stages operation

Permissible ambient conditions:

- Ambient temperature
- -10 to +40 °C (14 to 104F)
- -15 to +40 °C (5 to 104F)

Air humidity: max. 80 % relative humidity, no condensation.

The combustion air must be free of aggressive substances (halogens, chlorides, etc.) and impurities (dust, debris, vapors, etc.)

Emission:

The emissions have been measured in various models at the maximum output, according to DIN-EN 676 and DIN-EN 297 standard.

The values of CO and NOx during burner operation are lower than 30 and 120 mg/kWh at 20 % excess of air for normal versions and, lower than 20 and 80 mg/kWh for Low NOx versions (LN series). consequently, the burner's NOx class of II and III is reported and being approved for normal version and LN Versions respectively.

Special notes:

LN versions have a higher rate of mixing during their operation. This results a further decrease in the flame length and an increase in the flame diameter.

Flame dimension

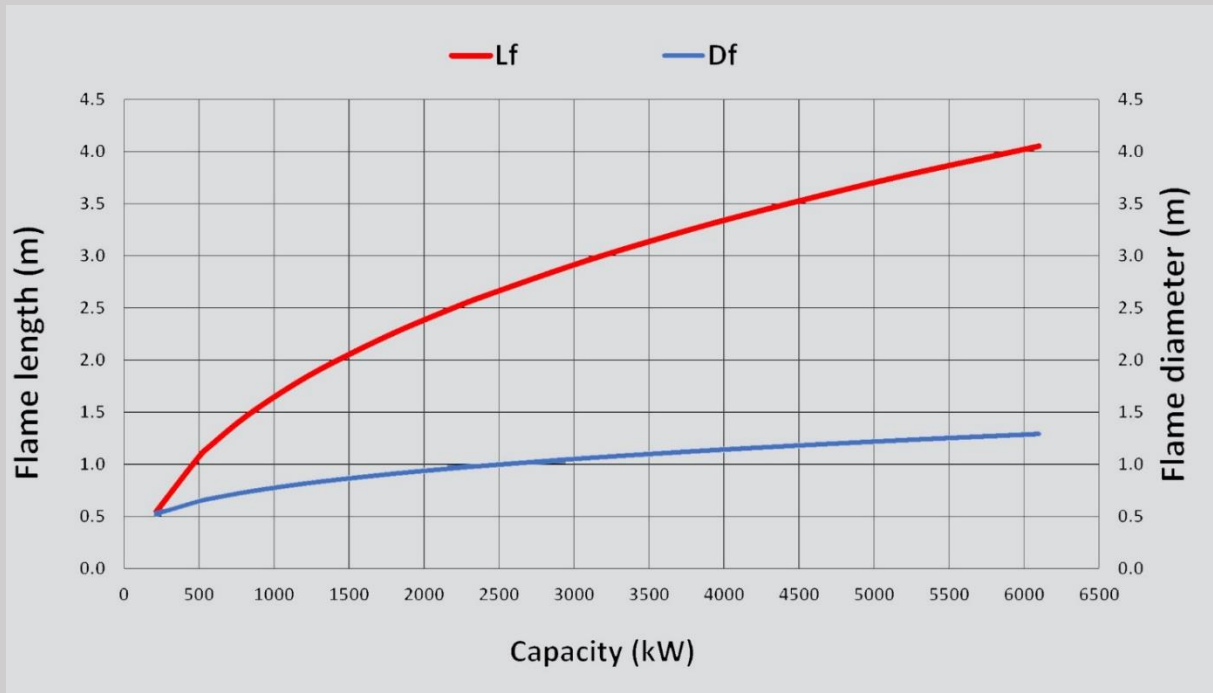

The flame dimensions which play an effective role in the burner efficiency and influence their compatibility to the boiler combustion chamber geometry, are presented in the above diagram.

Suggested combustion chamber dimension:

The raadman burners can be appropriately selected for all boilers which are designed according to the BS-2790, BS-855, EN-303, BS-EN 12953-3. It is recommended that a flame fill 90% of combustion chambers at its maximum output.

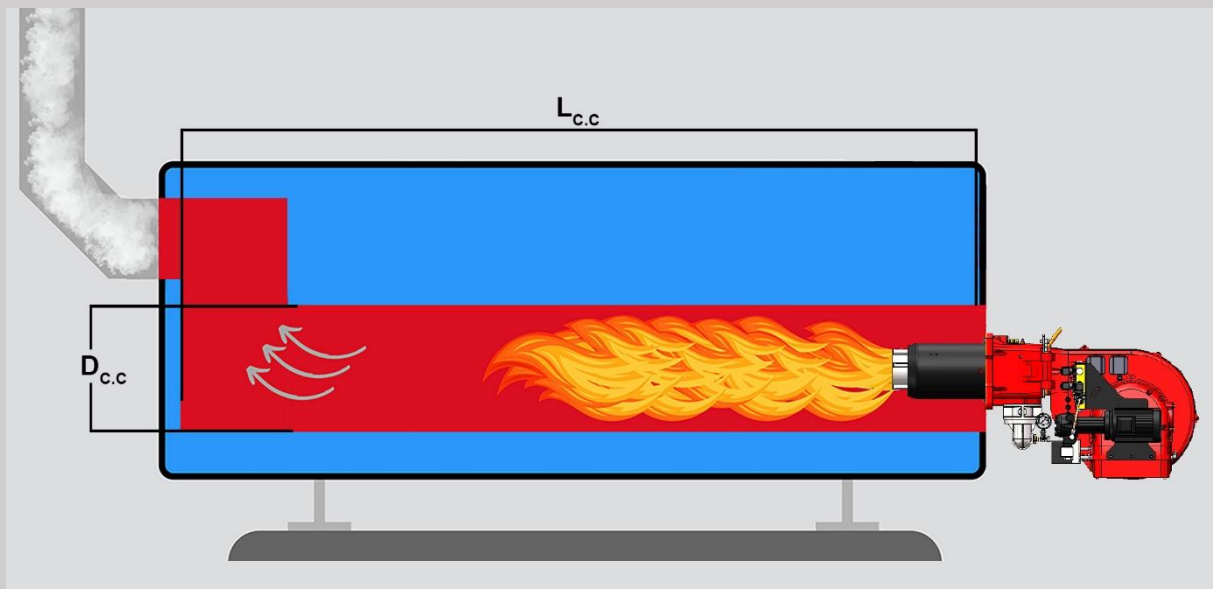
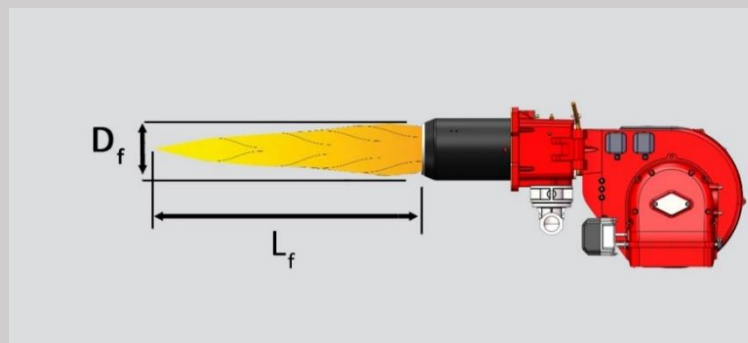

raadman RGB series burner

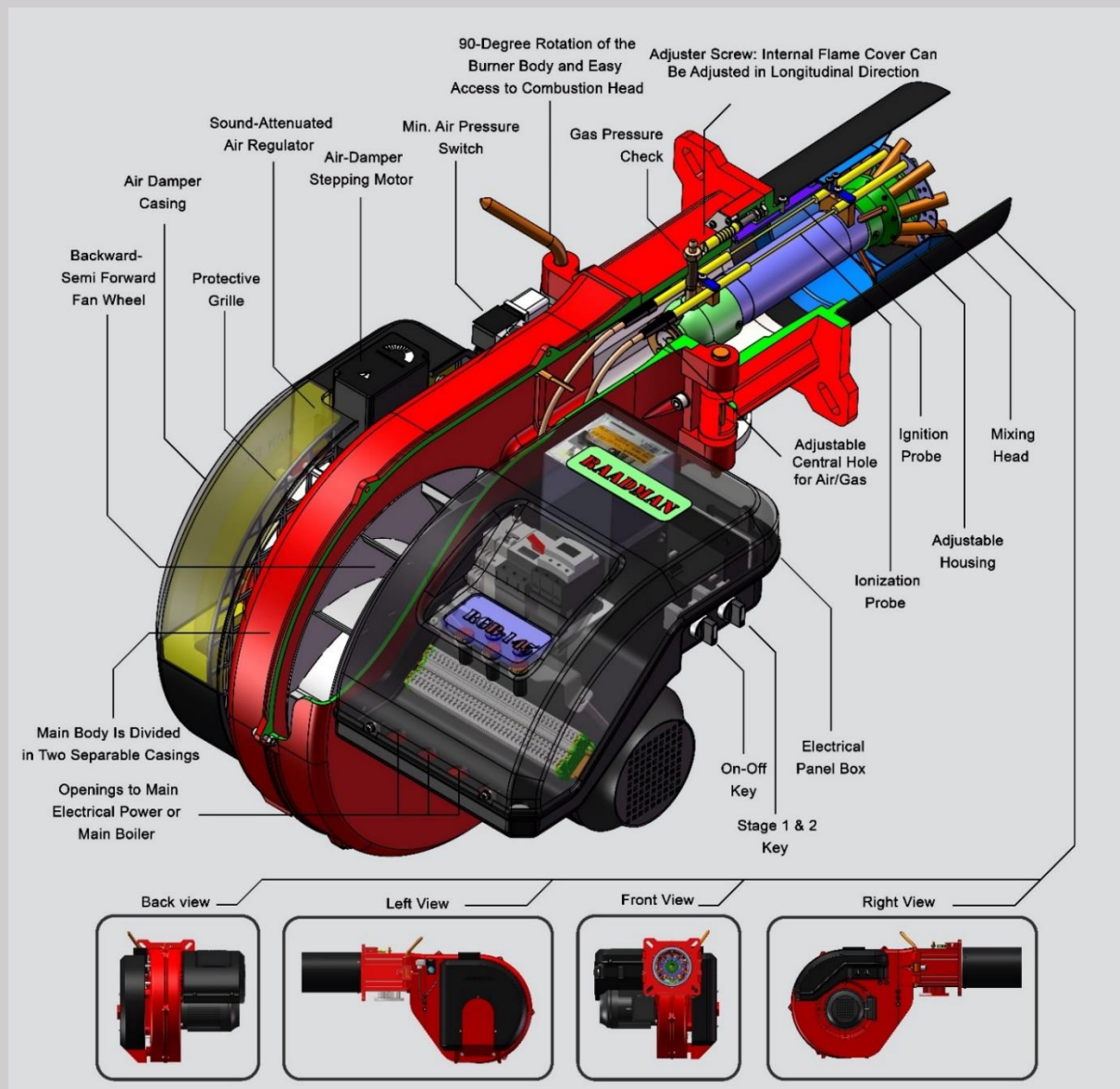

Burner selection: capacity and working diagram

Staging Gas Burner

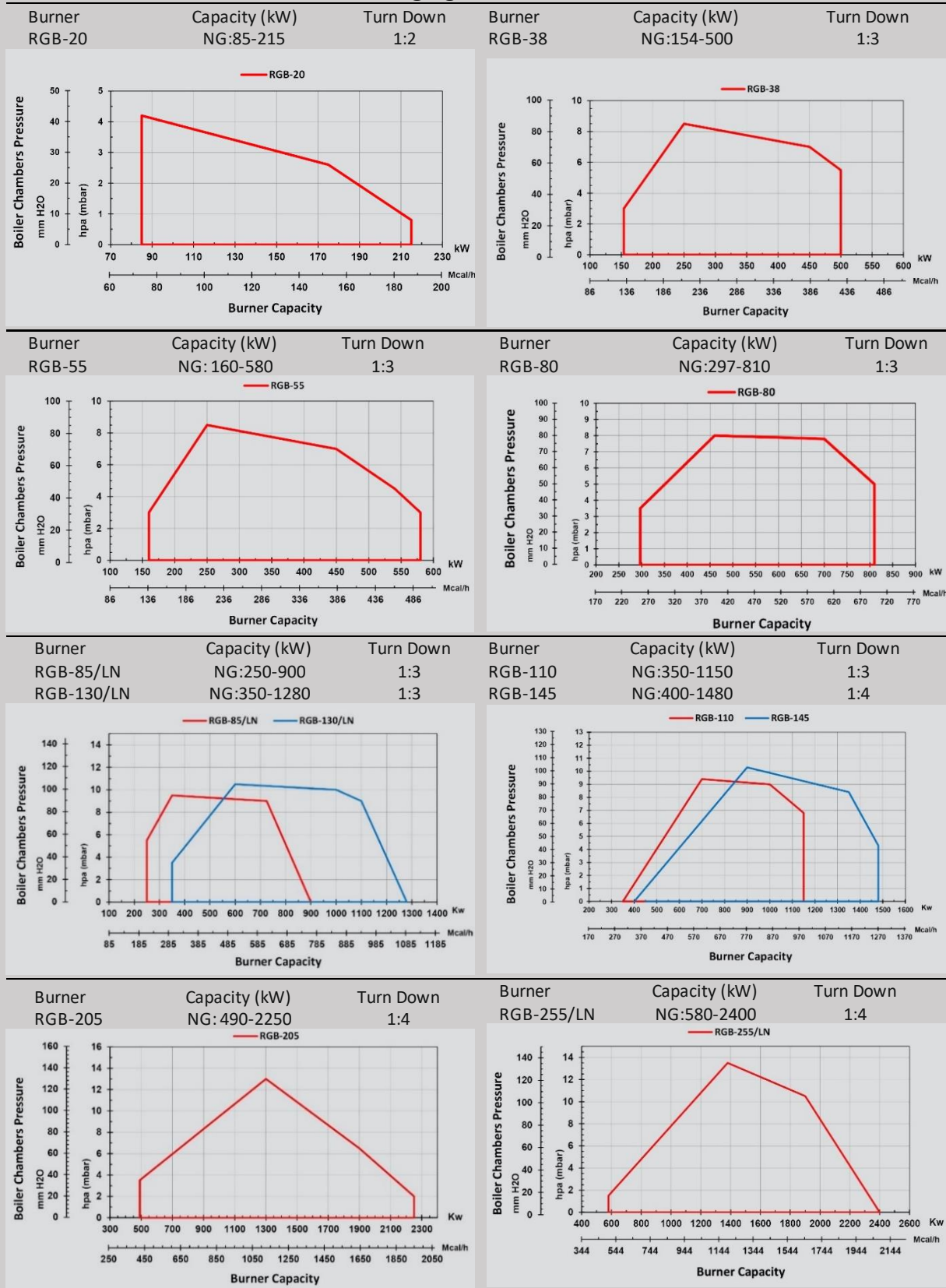

Burner	Capacity (kW)	Turn Down
RGB-305	NG: 600-3000	1:5
RGB-385	NG: 650-3800	1:5

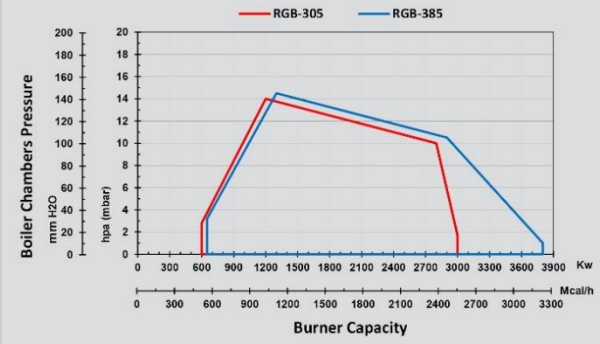

Burner	Capacity (kW)	Turn Down
RGB-405/LN	NG: 680-4100	1:6
RGB-505/LN	NG: 700-5100	1:7

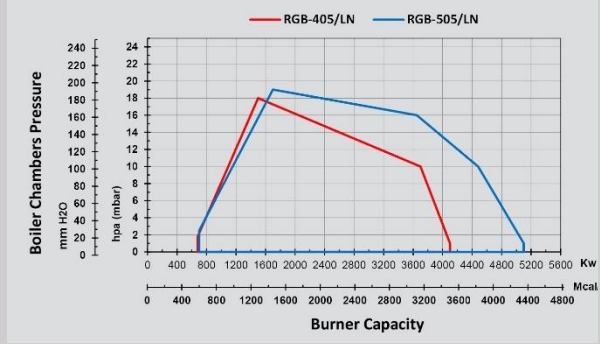

Burner	Capacity (kW)	Turn Down
RGB-605	NG: 850-6200	1:7

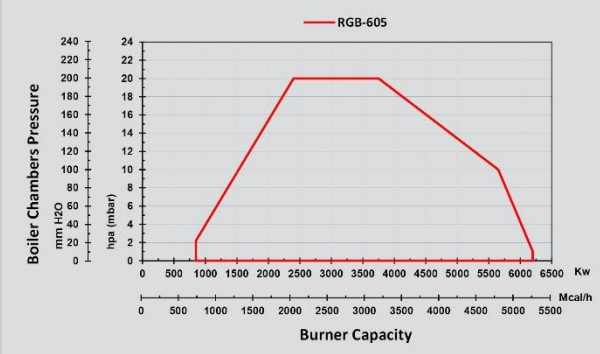

About working diagram

Working diagram for gas burner certified in accordance with EN 676.

The firing rate diagram has been obtained considering ambient temperature of 20°C and atmospheric pressure of 1013 mbar (Sea level condition). For installation at higher altitudes, a reduction in capacity of 1% per 100 m above sea level should be taken into account.



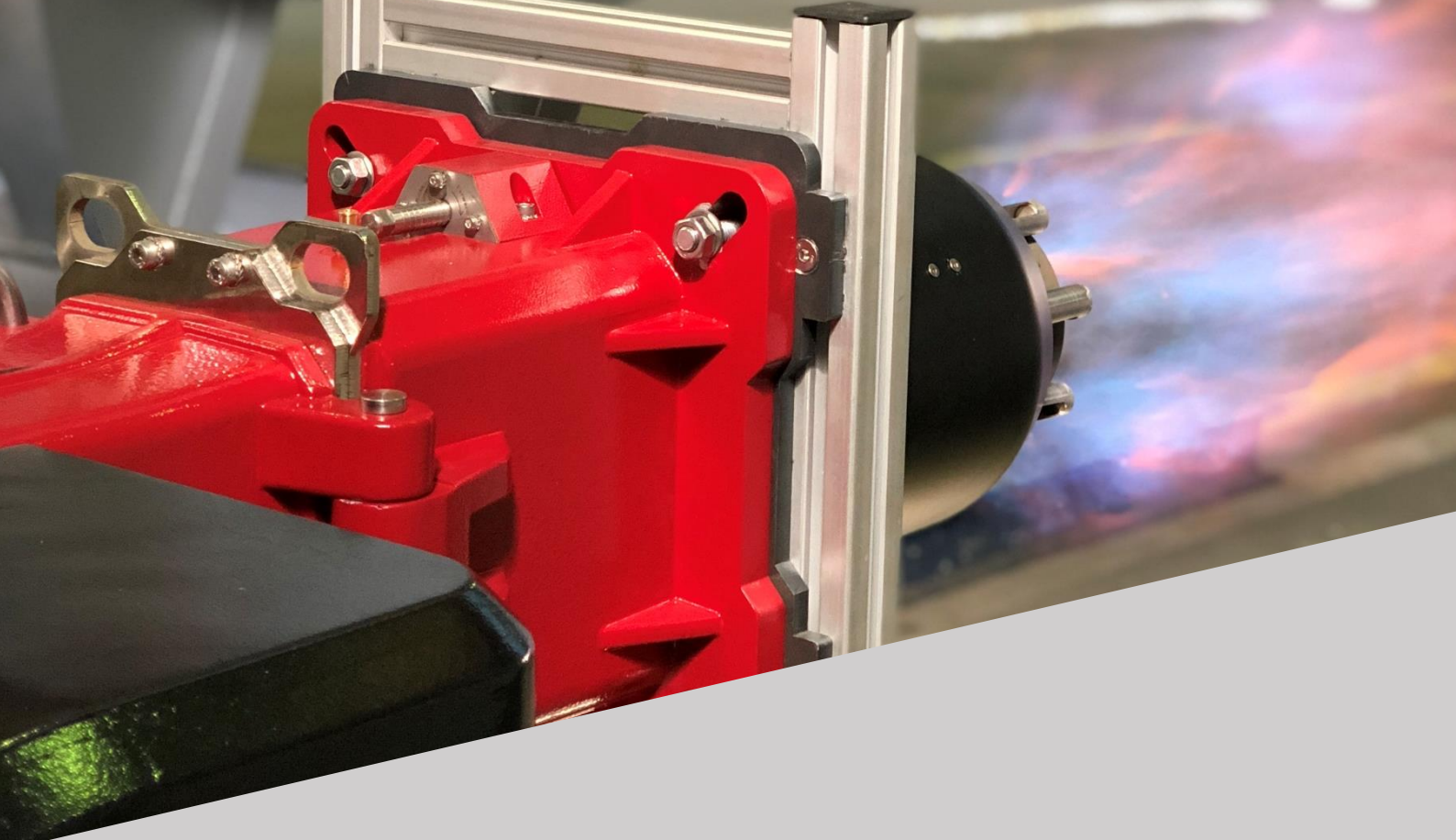

Technical data: RGB series

RGB burners include Ventilation system with AC motor, Ignition transformer, and electrodes, electrical panel with power contactors, fuses, relays, central controller, air pressure switches, soundproofing material, Lamp signals for operational supervision, etc.

Burner	Motor(kW/PH/V/HZ/rpm)	Controller	Actuator
RGB-20	0.3 /1 /220 /50 /2700	Shokouh	--
RGB-38	0.45 /3 /380-400 /50 /2700	Shokouh	--
RGB-55	0.75 /3 /380-400 /50 /2840	Shokouh	2.5
RGB-80	1.1 /3 /380-400 /50 /2850	Shokouh	2.5
RGB-85/LN	1.5 /3 /380-400 /50 /2840	Shokouh	2.5
RGB-110	1.5 /3 /380-400 /50 /2840	Siemens	3
RGB-130/LN	2.2 /3 /380-400 /50 /2840	Siemens	3
RGB-145	2.2 /3 /380-400 /50 /2840	Siemens	3
RGB-205	4 /3 /380-400 /50 /2840	Siemens	3
RGB-255/LN	5.5 /3 /380-400 /50 /2840	Siemens	3
RGB-305	7.5 /3 /380-400 /50 /2900	Siemens	3
RGB-385	7.5 /3 /380-400 /50 /2900	Siemens	3
RGB-405/LN	9.2 /3 /380-400 /50 /2900	Siemens	3
RGB-505/LN	11 /3 /380-400 /50 /2900	Siemens	3

General dimension: RGB series

RGB-20

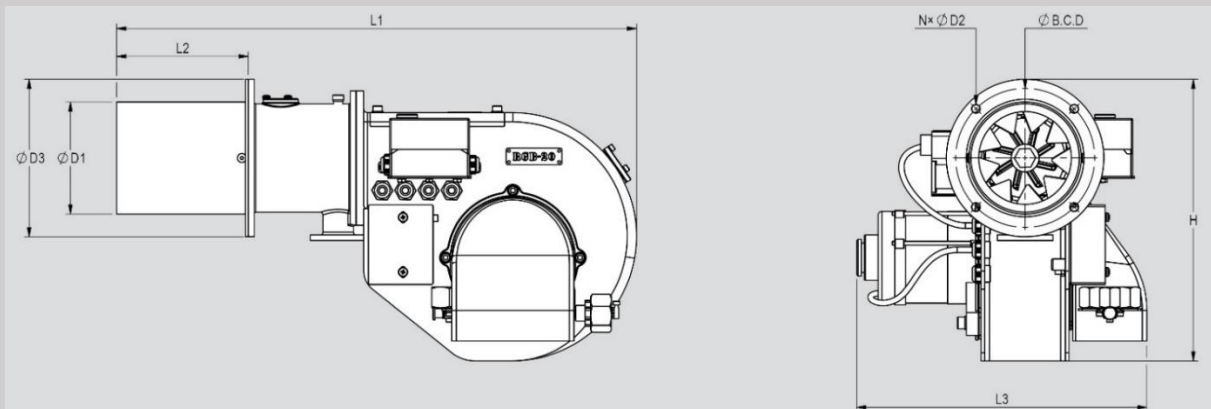

Burner Type	L ₁	L ₂	L ₃	H	D ₁	D ₂	D ₃	N	B.C. D
RGB-20	561	142	313	304	125	9	170	4	150

RGB-38, RGB-55

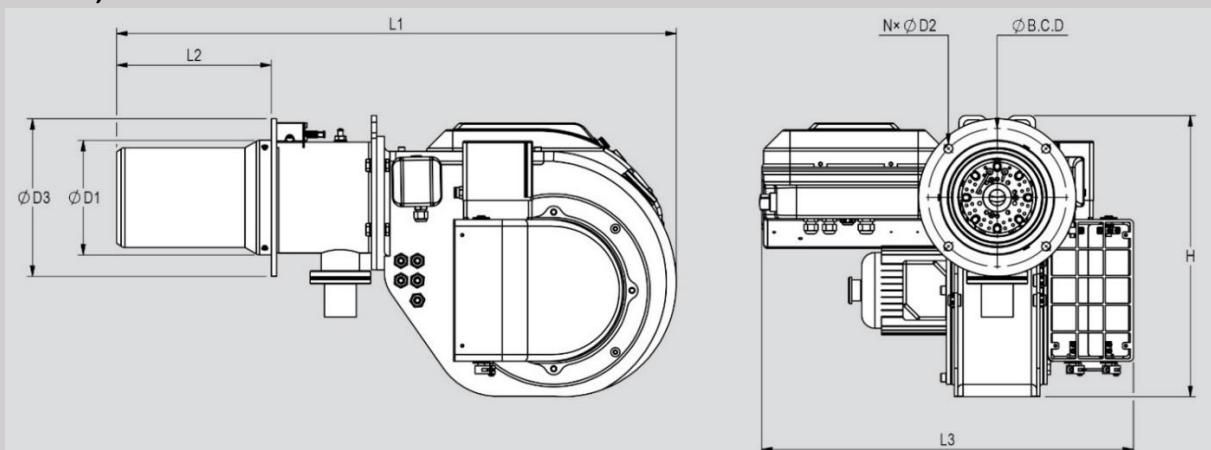

Burner Type	L ₁	L ₂	L ₃	H	D ₁	D ₂	D ₃	N	B.C. D
RGB-38	851	235	538	427	178	13.5	240	4	210
RGB-55	851	235	565	427	178	13.5	240	4	210

RGB-80

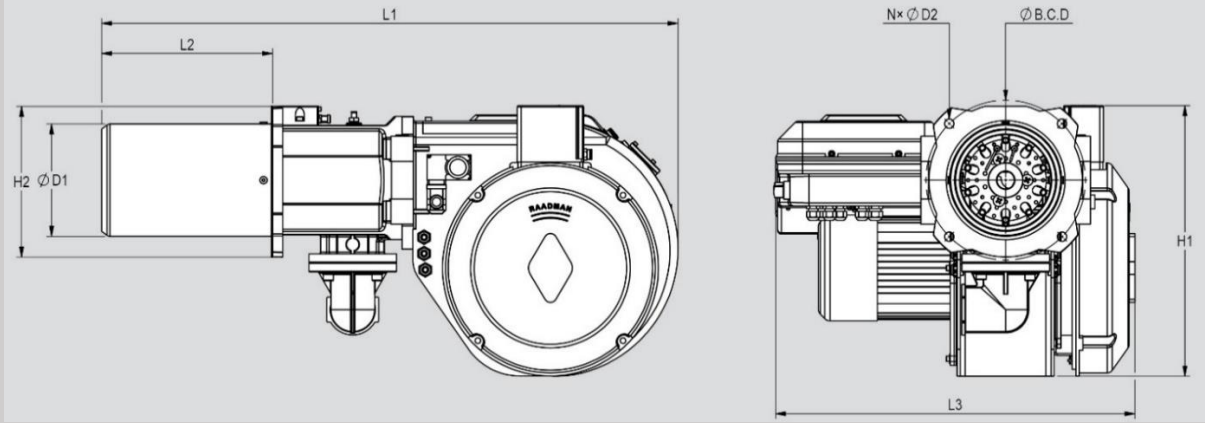

Burner Type	L ₁	L ₂	L ₃	H ₁	H ₂	D ₁	D ₂	N	B.C. D
RGB-80	921	273.5	574	432	241	183	15	4	255

RGB-85/LN, RGB-130/LN

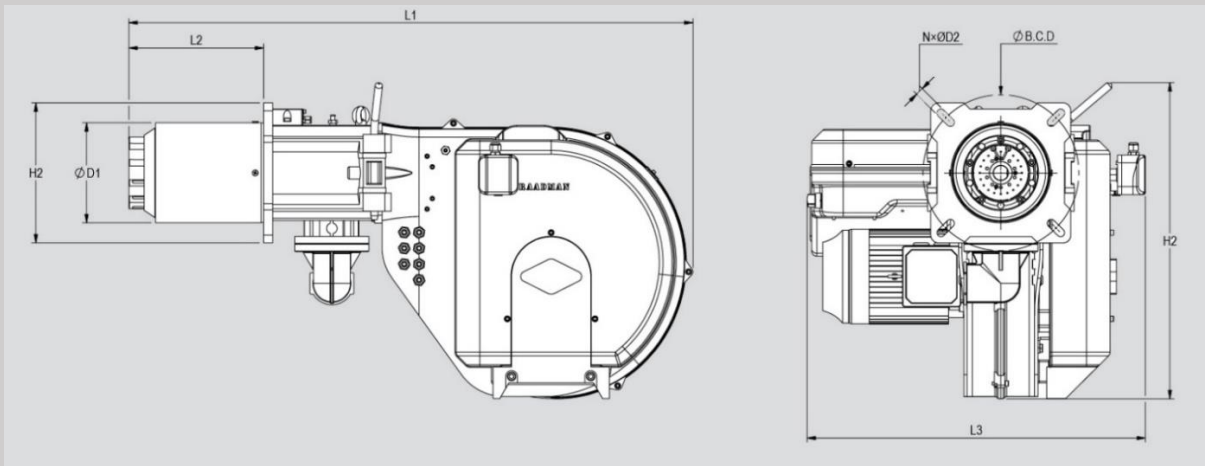

Burner Type	L ₁	L ₂	L ₃	H ₁	H ₂	D ₁	D ₂	N	B.C. D
RGB-85/LN	1068	255	582	600	265	190	15	4	295
RGB-130/LN	1068	255	582	600	265	190	15	4	295

RGB-110, RGB-145

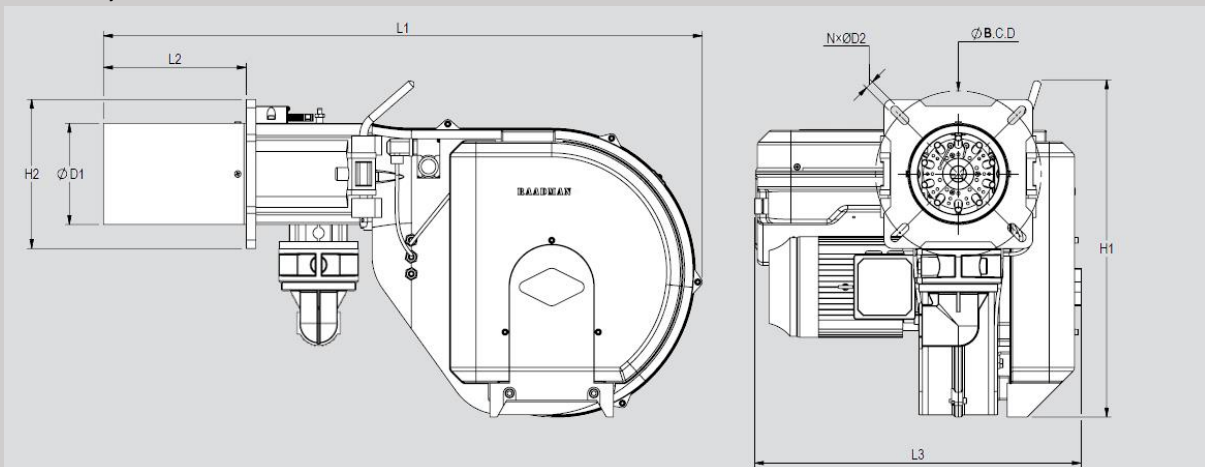

Burner Type	L ₁	L ₂	L ₃	H ₁	H ₂	D ₁	D ₂	N	B.C. D
RGB-110	1066	254	582	600	265	180	15	4	295
RGB-145	1097	285	582	600	265	189	15	4	295

RGB-205

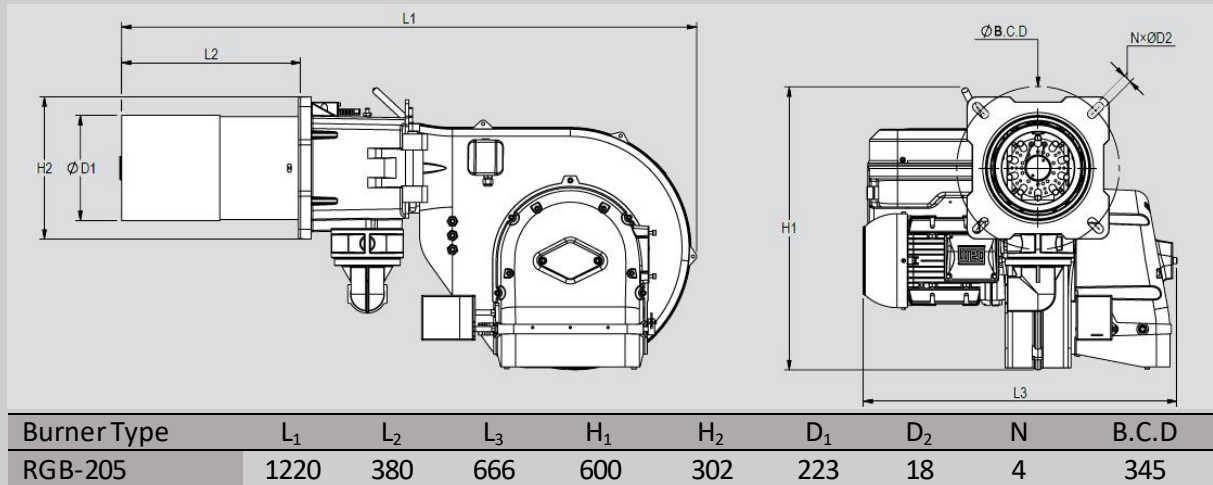

RGB-255/LN

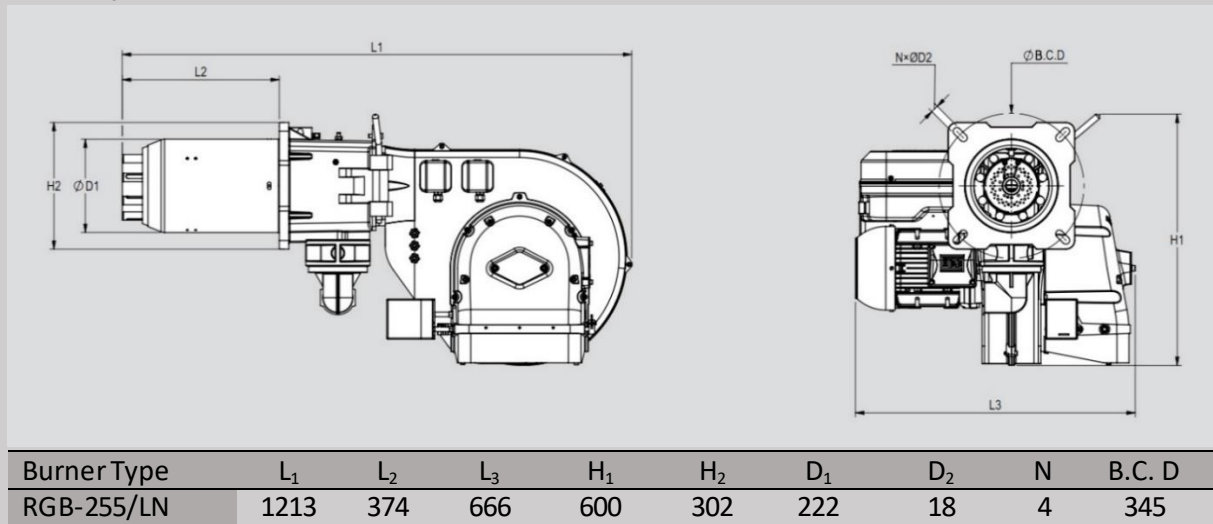

RGB-305, RGB-385

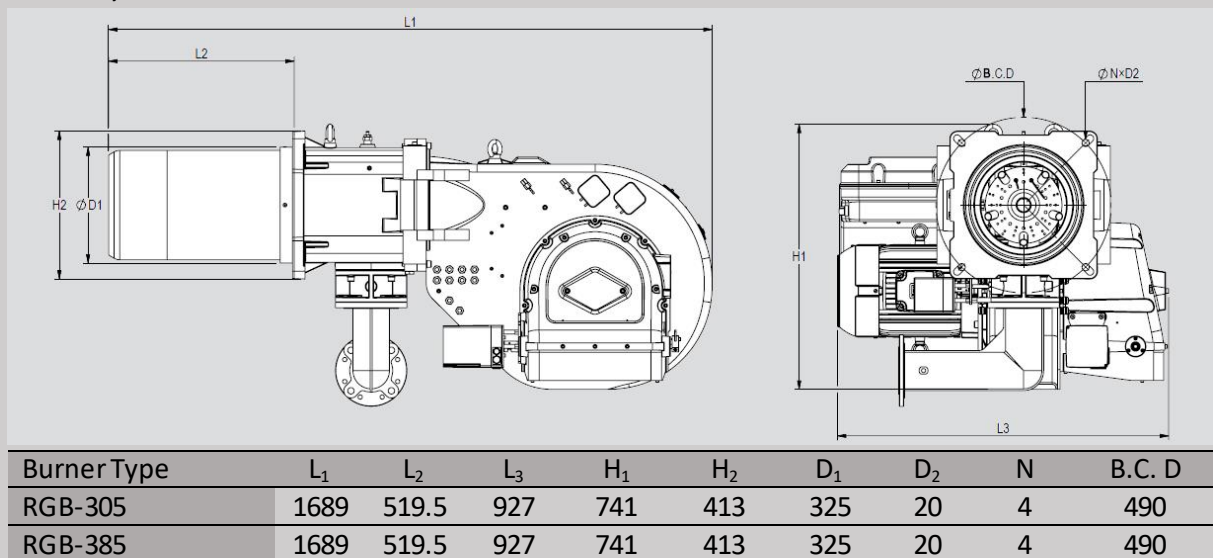

RGB-405/LN, RGB-505/LN

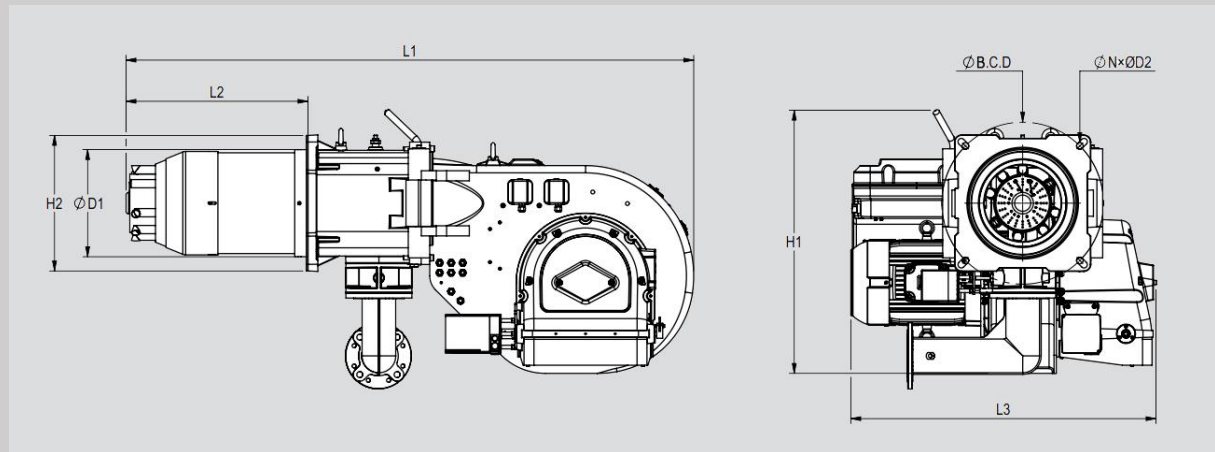

Burner Type	L ₁	L ₂	L ₃	H ₁	H ₂	D ₁	D ₂	N	B.C. D
RGB-405/LN	1720	552	925	797	413	324	20	4	490
RGB-505/LN	1720	552	925	797	413	324	20	4	490

RGB-605

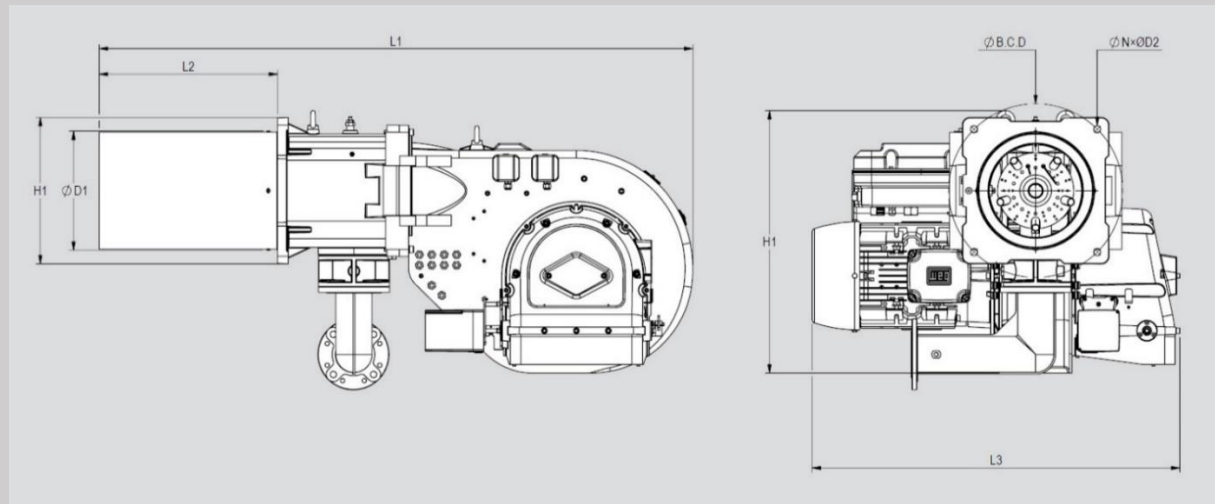

Burner Type	L ₁	L ₂	L ₃	H ₁	H ₂	D ₁	D ₂	N	B.C. D
RGB-605	1671	502	1036	741	413	336	20	4	490



We are delighted to gratefully guarantee the best performance of our productions in order to meet our customer demands.

RLGB series raadman burner

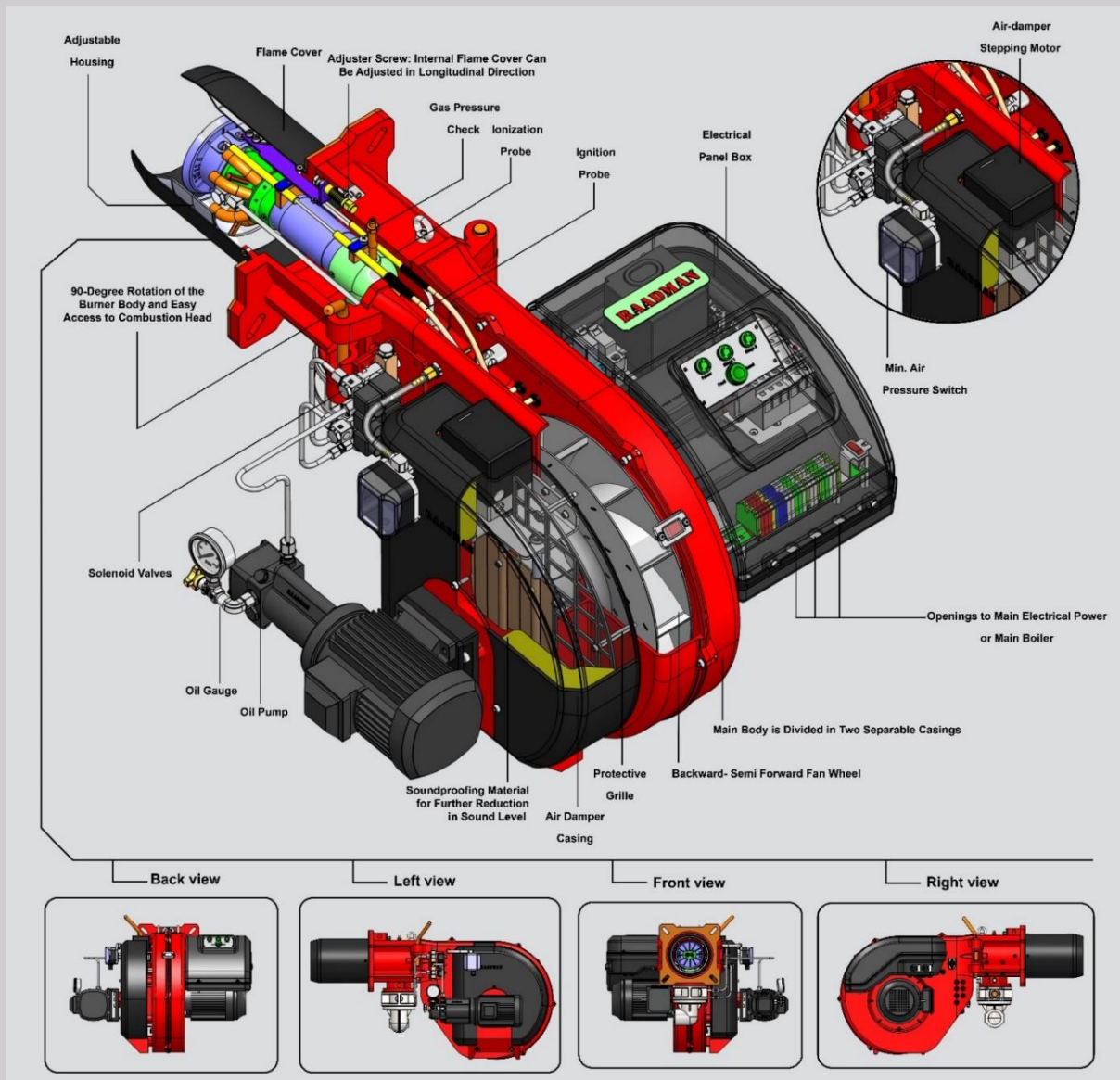

Burner selection: capacity and working diagram

Staging Dual-fuel Burner

Burner	Capacity (kW)	Turn Down	Burner	Capacity (kW)	Turn Down
RLGB-55	NG:160-580 LFO: 160-580	1:3 1:3	RLGB-85/LN	NG:297-810 LFO: 297-810	1:3 1:3

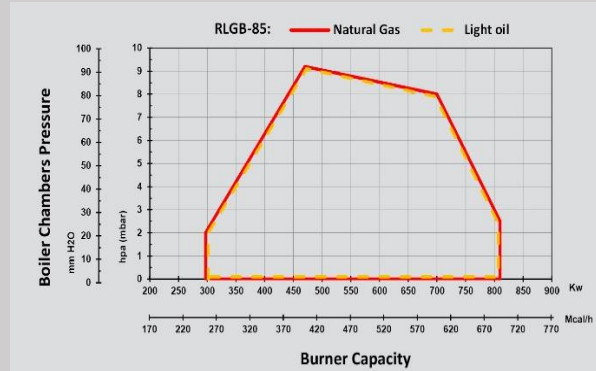

Burner	Capacity (KW)	Turn Down
RLGB-110	NG: 350-1100 LFO: 350-1100	1:3 1:3
RLGB-145	NG: 400-1380 LFO: 400-1380	1:4 1:4

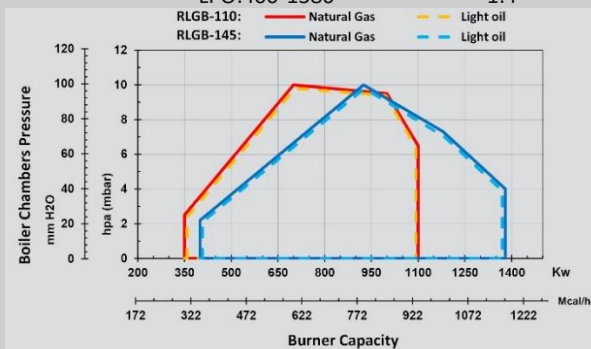

Burner	Capacity (kW)	Turn Down
RLGB-175/LN	NG:320-1800 LFO:320-1800	1:5 1:5
RLGB-205/LN	NG:450-2200 LFO:450-2200	1:5 1:5

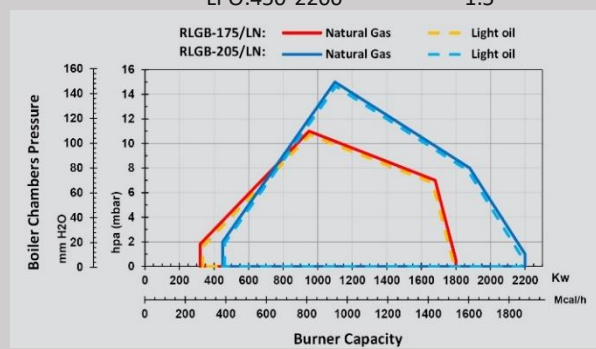

Burner	Capacity (kW)	Turn Down
RLGB-305/LN	NG: 600-3000 LFO: 600-3000	1:5 1:5
RLGB-385/LN	NG: 350-3500 LFO: 650-3500	1:5 1:5

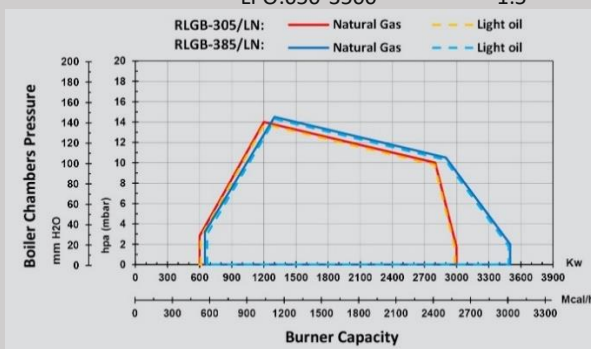

Burner	Capacity (kW)	Turn Down
RLGB-405/LN	NG: 680-4100 LFO: 680-4100	1:6 1:6
RLGB-505/LN	NG: 700-5100 LFO: 700-5100	1:7 1:7



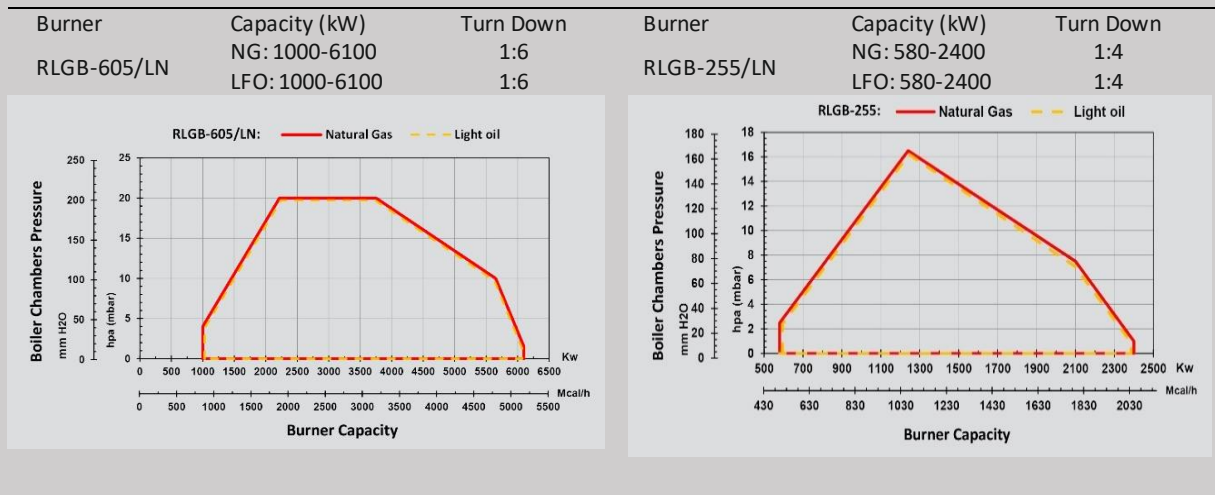

Working diagrams for light fuel oil burner are certified in accordance with EN 267.

The firing rate diagram has been obtained considering the ambient temperature of 20°C and atmospheric pressure of 1013 mbar (Sea level condition).



Technical data: RLGB series

RLGB burners include: Ventilation system with AC motor, Ignition transformer and electrodes, electrical panel with power contactors, fuses, relays, central controller, air pressure switches, Oil delivery solenoid valves and pressure gauges plus pump and AC motor with return and feed pipes, sound proofing material, Lamp signals for operational supervision etc.

Burner	Motor(kW/PH/V/HZ/rpm)	Controller	Actuator (N.m)
RLGB-55	0.75/3/380-400/50/2850	Shokouh	2.5
RLGB-85	1.1 /3 /380-400 /50 /2840	Shokouh	2.5
RLGB-110	1.5 /3 /380-400 /50 /2840	Siemens	3
RLGB-145	2.2 /3 /380-400 /50 /2840	Siemens	3
RGB-175/LN	4 /3 /380-400 /50 /2840	Siemens	3
RLGB-205/LN	5.5 /3 /380-400 /50 /2840	Siemene	3
RLGB-255	5.5 /3 /380-400 /50 /2840	Siemens	3
RLGB-305/LN	7.5 /3 /380-400 /50 /2940	Siemens	9
RLGB-385/LN	7.5 /3 /380-400 /50 /2940	Siemens	9
RLGB-405/LN	9.2 /3 /380-400 /50 /2940	Siemens	9
RLGB-505/LN	11 /3 /380-400 /50 /2940	Siemens	9
RLGB-605/LN	15 /3 /380-400 /50 /2920	Siemens	9

General dimension: RLGB series

RLGB-55

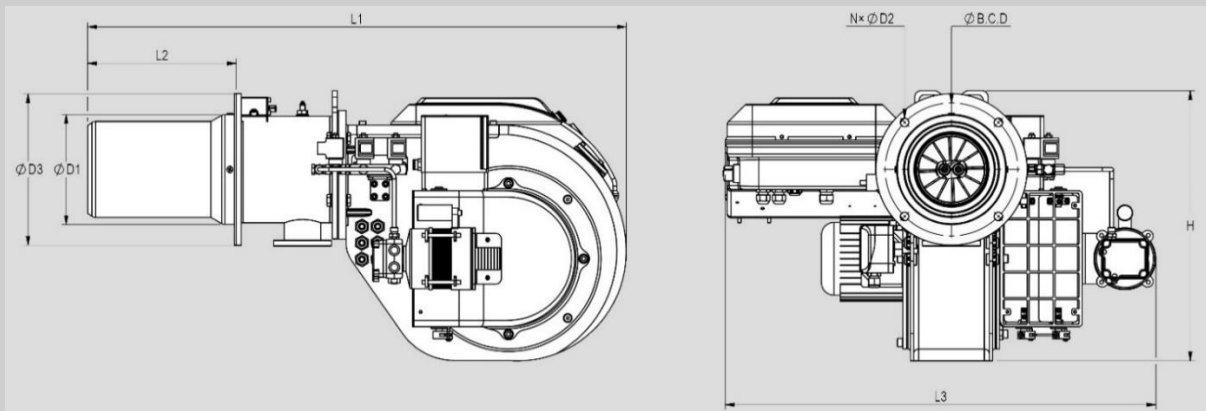

Burner Type	L ₁	L ₂	L ₃	H	D ₁	D ₂	D ₃	N	B.C. D
RLGB-55	853	235	682	427	178	13.5	240	4	210

RLGB-85

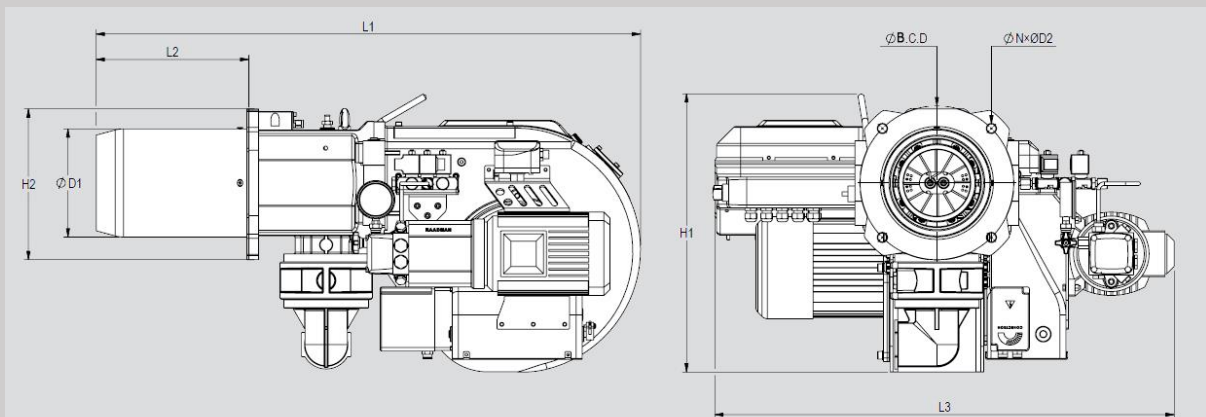

Burner Type	L ₁	L ₂	L ₃	H ₁	H ₂	D ₁	D ₂	N	B.C. D
RLGB-85	902	253	760	461	250	182	15	4	255

RLGB-110, RLGB-145

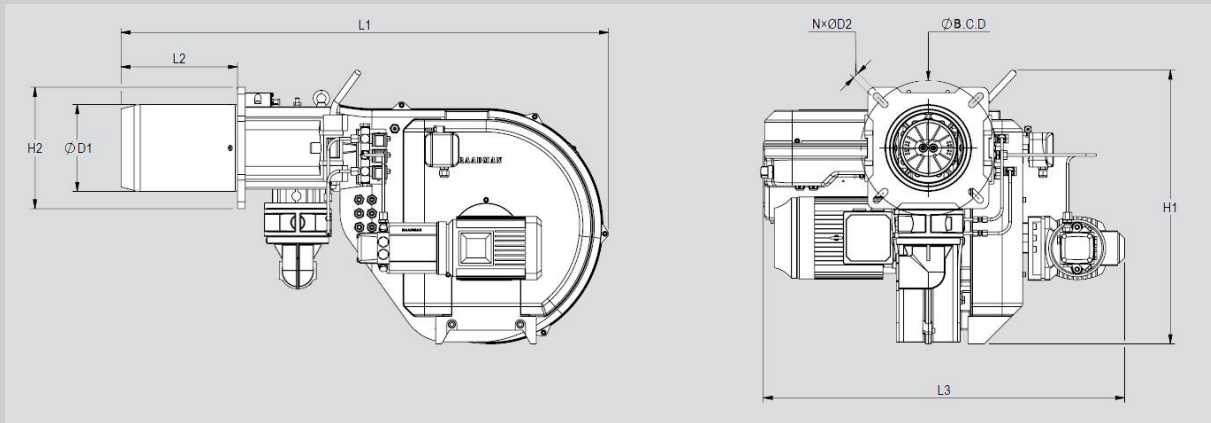

Burner Type	L ₁	L ₂	L ₃	H ₁	H ₂	D ₁	D ₂	N	B.C. D
RLGB-110	1068	255	797	600	265	180	15	4	295
RLGB-145	1068	255	797	600	265	180	15	4	295

RLGB-175/LN, RLGB-205/LN

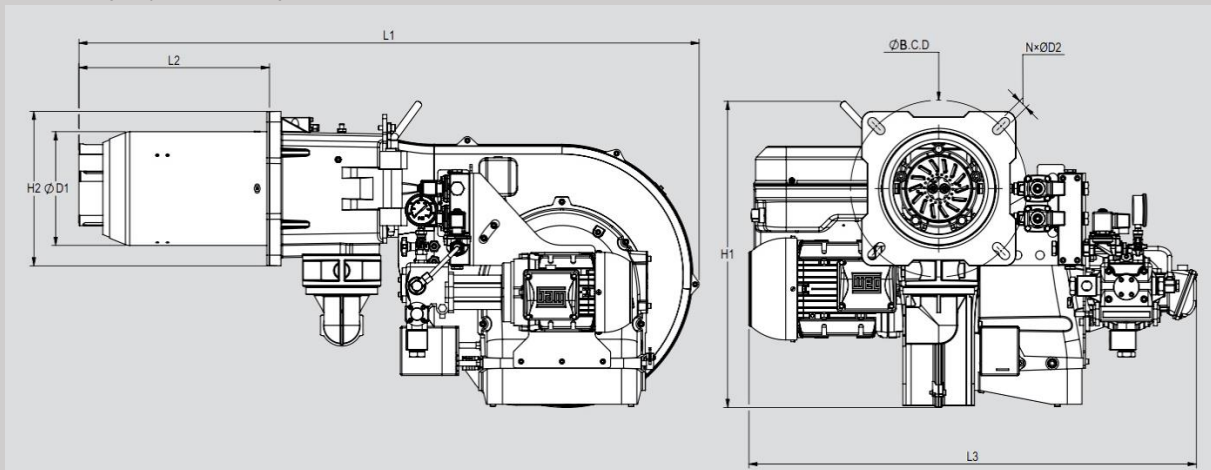

Burner Type	L ₁	L ₂	L ₃	H ₁	H ₂	D ₁	D ₂	N	B.C. D
RLGB-175/LN	1213	373	875	600	302	223	15	4	345
RLGB-205/LN	1213	373	875	600	302	223	15	4	345

RLGB-255

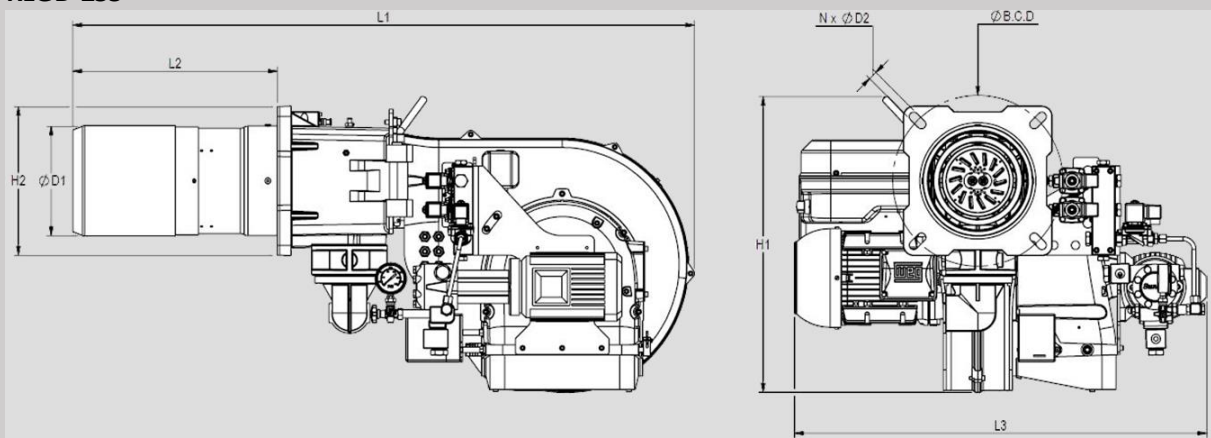

Burner Type	L ₁	L ₂	L ₃	H ₁	H ₂	D ₁	D ₂	N	B.C. D
RLGB-255	1260	419	833	600	302	224	18	4	345

RLGB-305/LN, RLGB-385/LN, RLGB-405/LN, RLGB-505/LN, RLGB-605/LN

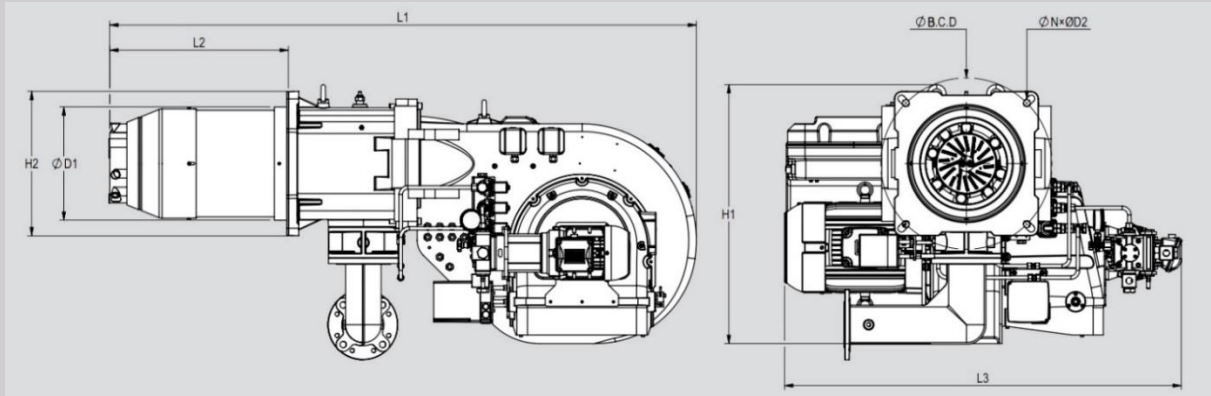

Burner Type	L ₁	L ₂	L ₃	H ₁	H ₂	D ₁	D ₂	N	B.C. D
RLGB-305/LN	1681	514	1137	741	413	328	20	4	490
RLGB-385/LN	1681	514	1137	741	413	328	20	4	490
RLGB-405/LN	1682	514	1141	741	413	328	20	4	490
RLGB-505/LN	1682	514	1141	741	413	328	20	4	490
RLGB-605/LN	1680	512	1274	741	413	340	20	4	490

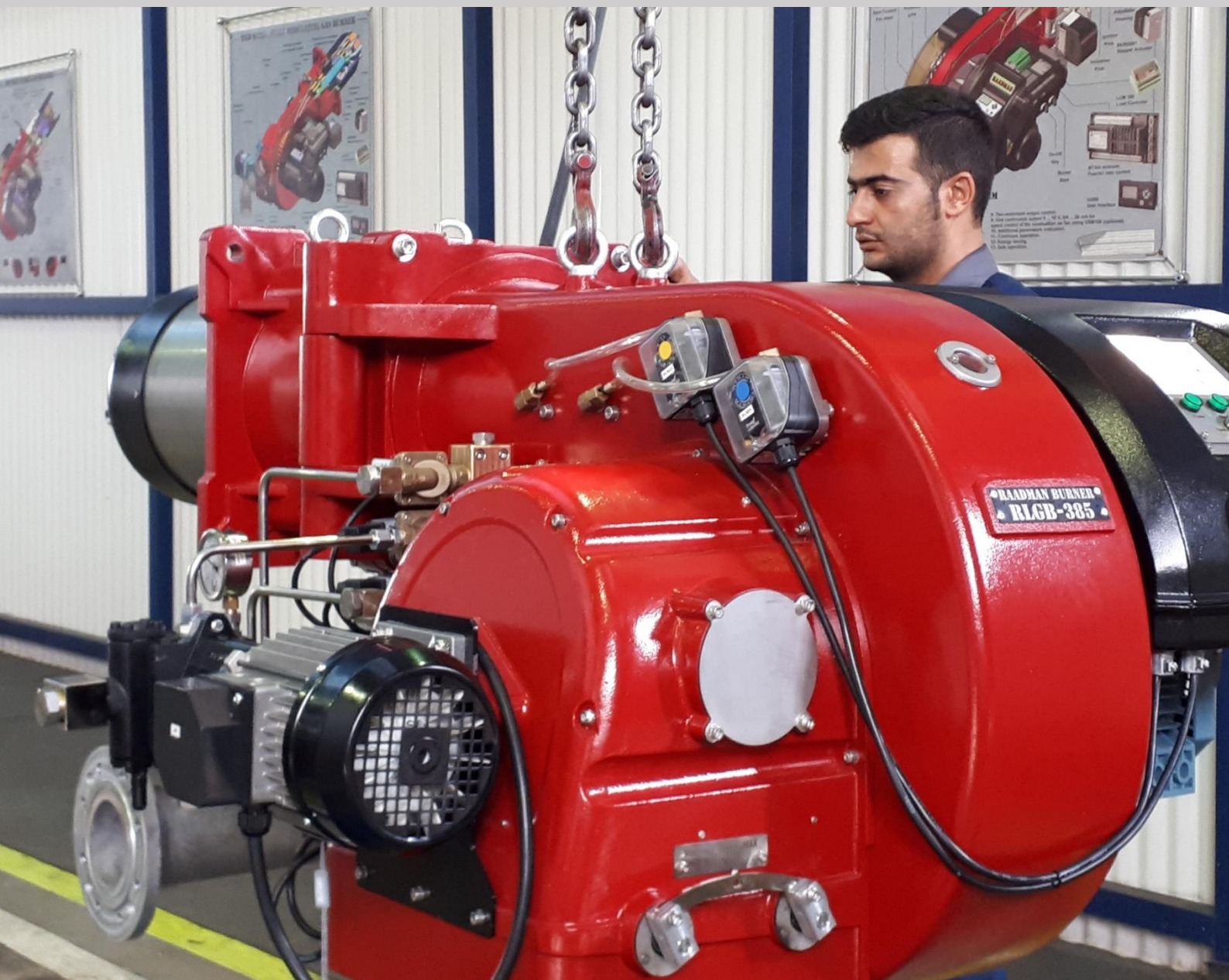

Gas train diagram

GT1

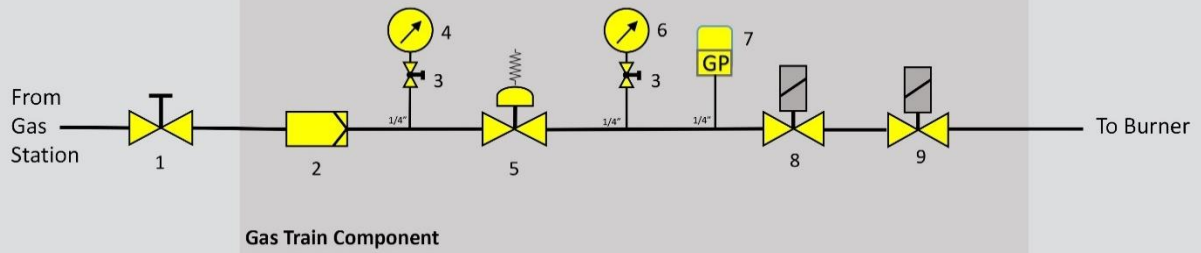

GT2

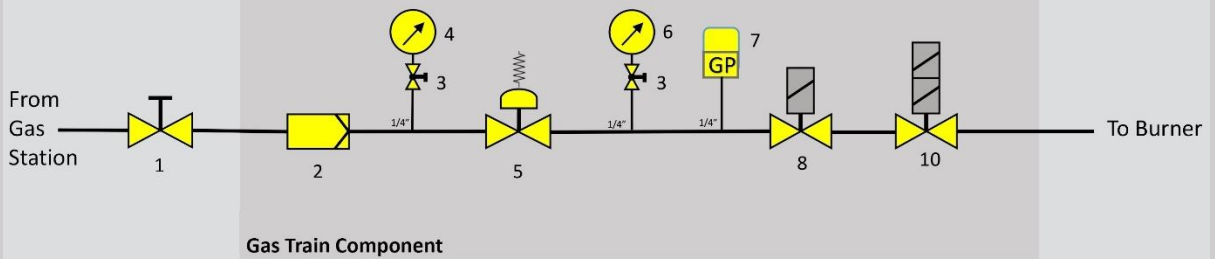

GT3

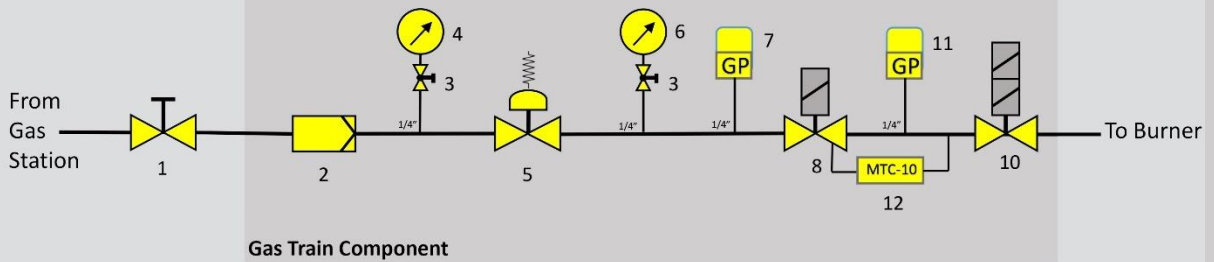

GT4

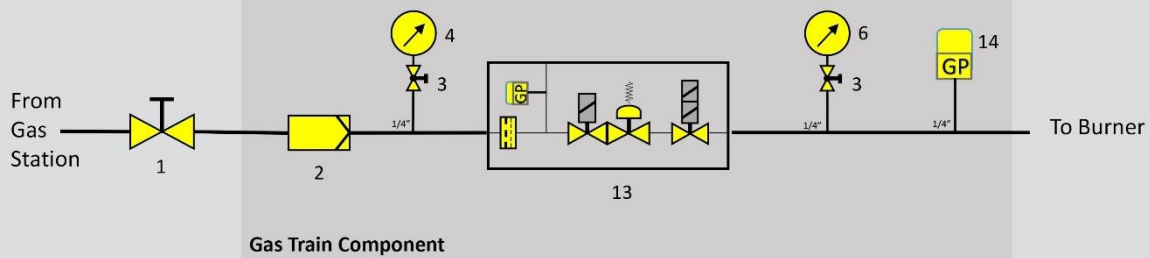

GT5

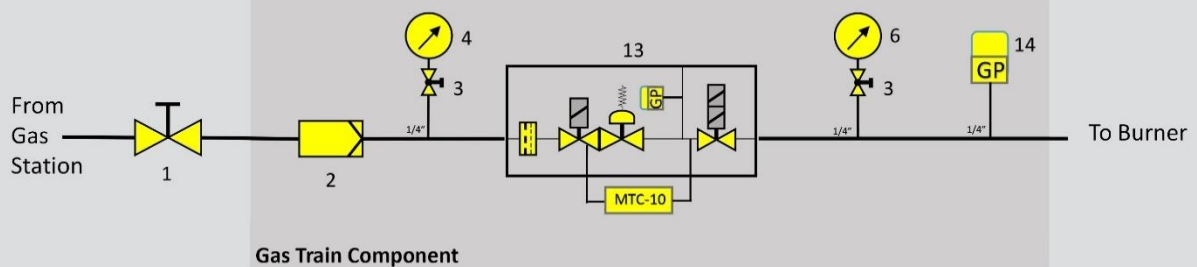

GT6

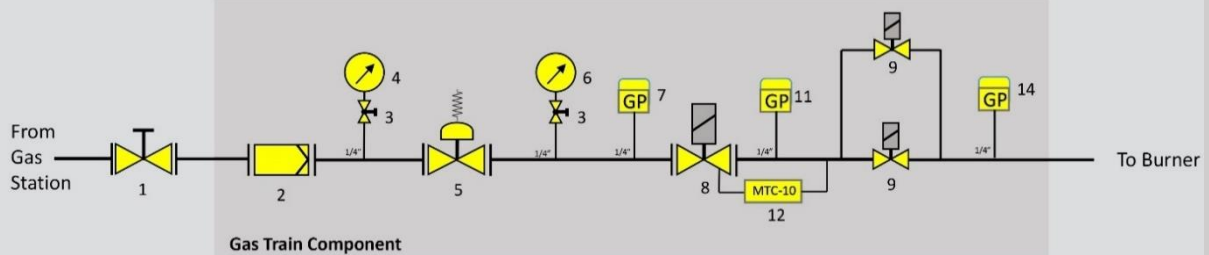

- | | | |
|----------------------|--------------------------------------|-------------------------------|
| 1. Manual Valve | 6. Pressure Gauge | 11. Leak Test Pressure Switch |
| 2. Gas Filter | 7. Min gas pressure switch | 12. Valve Proving System |
| 3. Push bottom valve | 8. Safety Solenoid Valve | 13. Multi-Bloc Solenoid Valve |
| 4. Pressure Gauge | 9. Stage Solenoid Valve | 14. Max. gas pressure Switch |
| 5. Regulator | 10. Stage Solenoid Valve (Two Stage) | |

Note:

According to the BS-EN 676, valve proving system shall be used in burners with capacity above 1.2 MW. Consequently, MADAS-MTC10 or DungsVDK200 valve proving system are highly recommended.

Layout of the valve train

On boilers with hinged doors, the valve train must be mounted on the opposite side to the boiler door hinges.

Break points in the valve train

Break points in the valve train should be provided to enable the door of the heat generator to be swung open. The main gas line is best separated at the compensator.

Support of the valve train

The valve train should be properly supported in accordance with the site conditions. See the radman accessories list for various valve train support components.

Gas train sizing

RGB series					
Burner	Gas model	Gas train size	Main Solenoid valve size	$\Delta P B. V^*$	$\Delta P C.H^{**}$ (mbar)
RGB-20	GT1	Rp 1	Rp 1	-	0
RGB-38	GT1	Rp 1 ½	Rp 1 ½	-	5.6
RGB-55	GT2	Rp 1 ½	Rp 1 ½	-	7.2
	GT4	Rp 1 ½	Rp 1 ½		
RGB-80	GT2	Rp 1 ½	Rp 1 ½	-	10.3
	GT4	Rp 1 ½	Rp 1 ½		
RGB-85/LN	GT2	Rp 1 ½	Rp 1 ½	-	11.7
	GT4	Rp 1 ½	Rp 1 ½		
RGB-110	GT2	Rp 2	Rp 1 ½	-	9
	GT4	Rp 2	Rp 1 ½		
RGB-130/LN	GT3	Rp 2	Rp 2	-	22.5
	GT5	Rp 2	Rp 2		
RGB-145	GT3	Rp 2	Rp 2	-	8.6
	GT5	Rp 2	Rp 2		
RGB-205	GT3	Rp 2	Rp 2	-	14.5
RGB-255/LN	GT3	DN 65	Rp 2	-	24.9
RGB-305***	GT6	DN 65	Rp 2	-	20.6
RGB-385***	GT6	DN 65	Rp 2	-	31.7
RGB-405/LN***	GT6	DN 65	Rp 2	-	47
RGB-505/LN***	GT6	DN 65	Rp 2	-	56
RGB-605***	GT6	DN 65	Rp 2	-	62.8

RLGB series					
Burner	Gas model	Gas train size	Main Solenoid valve size	$\Delta P B. V^*$	$\Delta P C.H^{**}$ (mbar)
RLGB-55	GT2	Rp 1 ½	Rp 1 ½	-	14
	GT4	Rp 1 ½	Rp 1 ½		
RLGB-85	GT2	Rp 1 ½	Rp 1 ½	-	6.2
	GT4	Rp 1 ½	Rp 1 ½		
RLGB-110	GT2	Rp 2	Rp 1 ½	-	10
	GT4	Rp 2	Rp 1 ½		
RLGB-145	GT3	Rp 2	Rp 1 ½	-	13
	GT5	Rp 2	Rp 1 ½		
RLGB-175/LN	GT3	Rp 2	Rp 2	-	17
	GT5	Rp 2	Rp 2		
RLGB-205/LN	GT3	Rp 2	Rp 2	-	21.5
RLGB-255***	GT6	DN 65	Rp 2	-	27.8
RLGB-305/LN***	GT6	DN 65	Rp 2	-	23
RLGB-385/LN***	GT6	DN 65	Rp 2	-	27.3
RLGB-405/LN***	GT6	DN 65	Rp 2	-	44
RLGB-505/LN***	GT6	DN 65	Rp 2	-	47
RLGB-605/LN***	GT6	DN 65	Rp 2	-	68

*Butterfly Valve: In raadman-Staging version, since there is no link between air and gas inlets, no butterfly valve is used. As a result, its relative pressure drop is considered to zero.

**Combustion Head

*** Due to the uncommon type of this gas train (GT6), the Mechanical Staging operation type is more favorable for this firing rate of burners.

Calculation of minimum inlet pressure and minimum output pressure of regulator

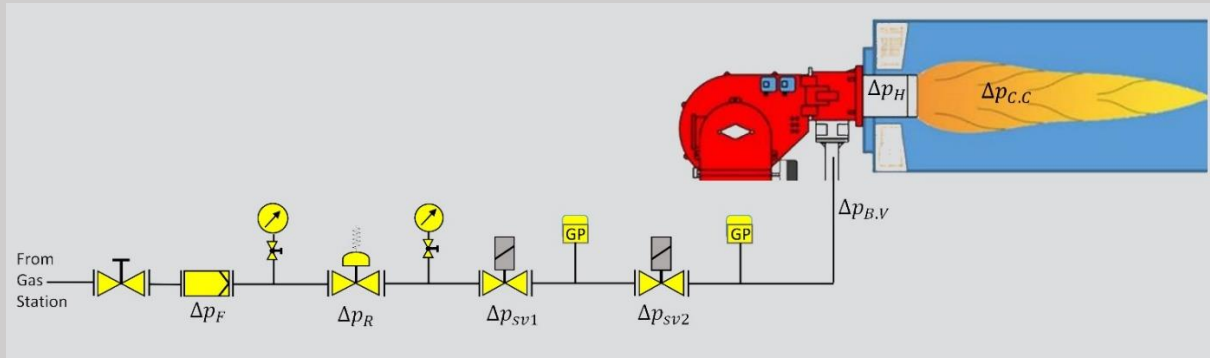

$$\text{Min input pressure} = \Delta P_{\text{Filter(F)}} + \Delta P_{\text{Regulator(R)}} + \Delta P_{\text{Safety solenoid valve(sv1)}} + \Delta P_{\text{Main solenoid valve(sv2)}} + \Delta P_{\text{Butterfly valve(B.V)}} + \Delta P_{\text{Combustion Head(C.H)}} + \Delta P_{\text{Combustion chamber(C.C)}}$$

$$\text{Min output pressure of regulator} = \Delta P_{\text{Safety solenoid valve(sv1)}} + \Delta P_{\text{Main solenoid valve(sv2)}} + \Delta P_{\text{Butterfly valve(B.V)}} + \Delta P_{\text{Combustion Head(C.H)}} + \Delta P_{\text{Combustion chamber(C.C)}}$$

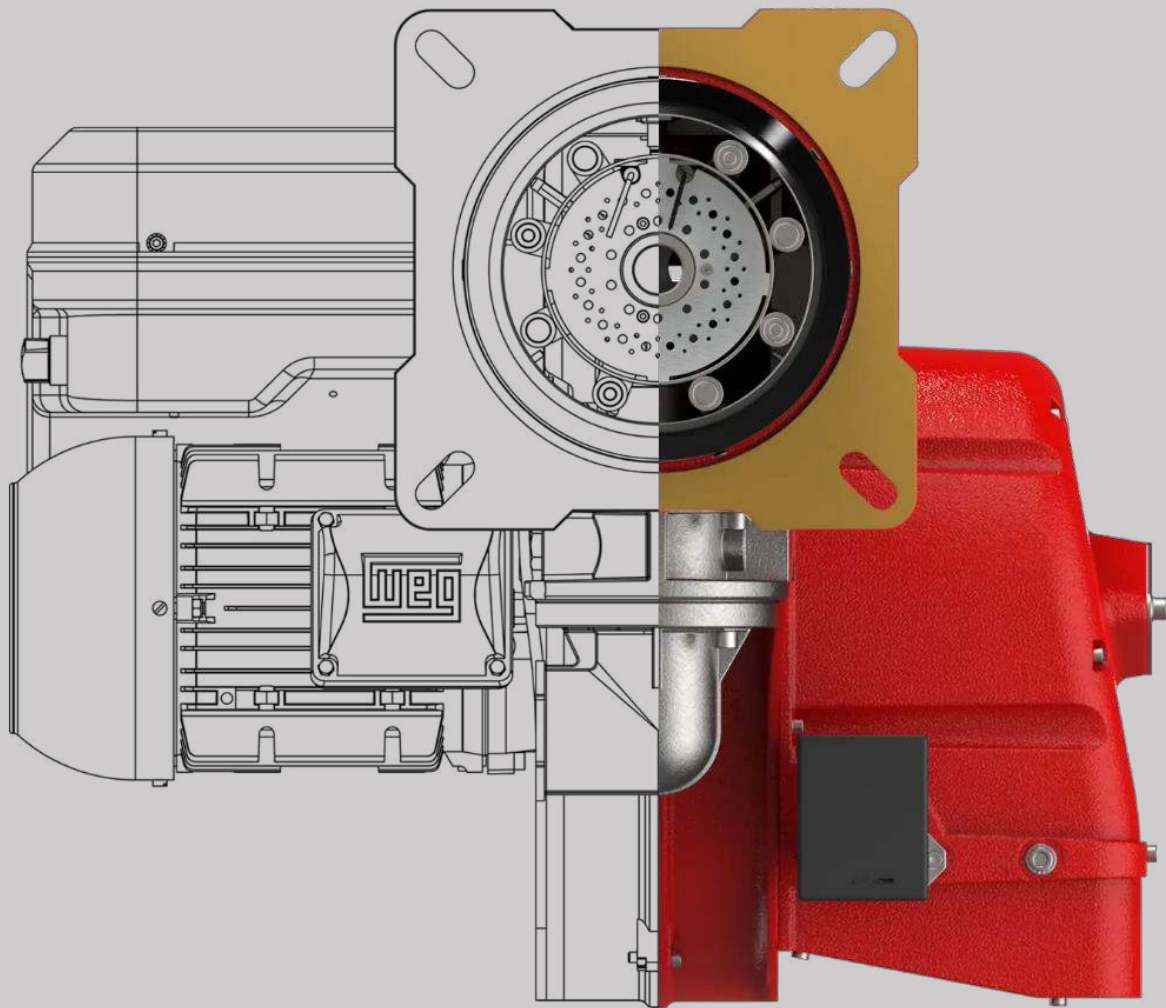

Oil delivery system

Two stages dual-fuel burner

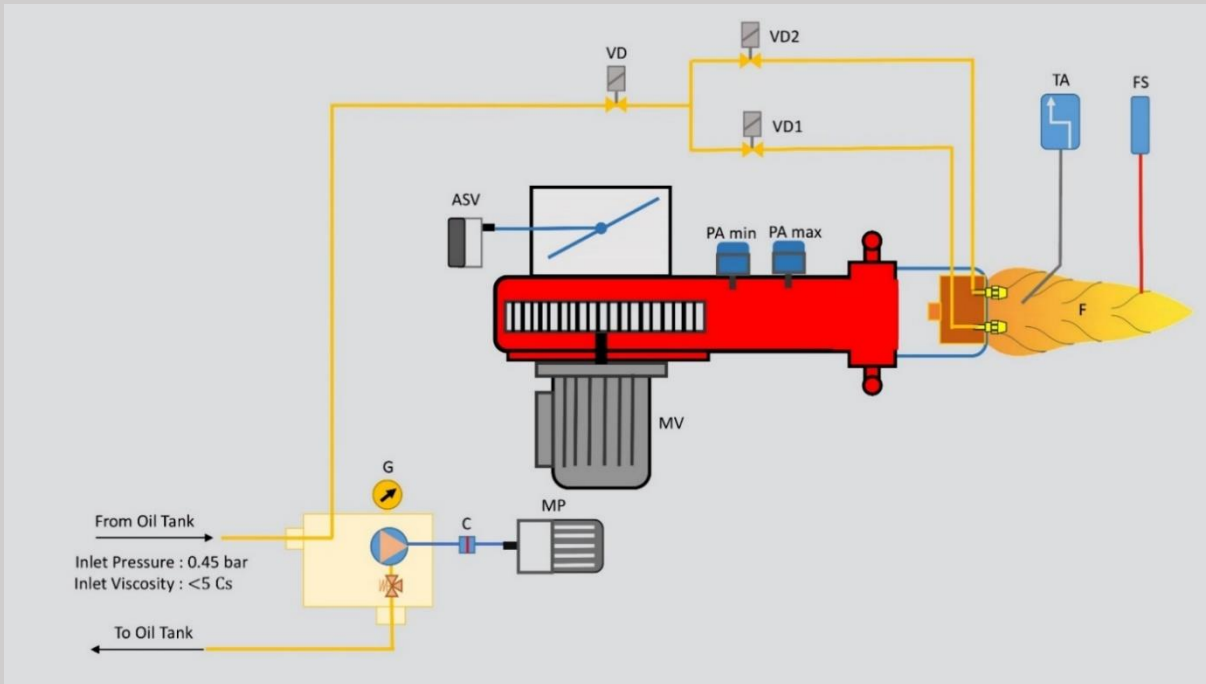

Three stages dual-fuel burner

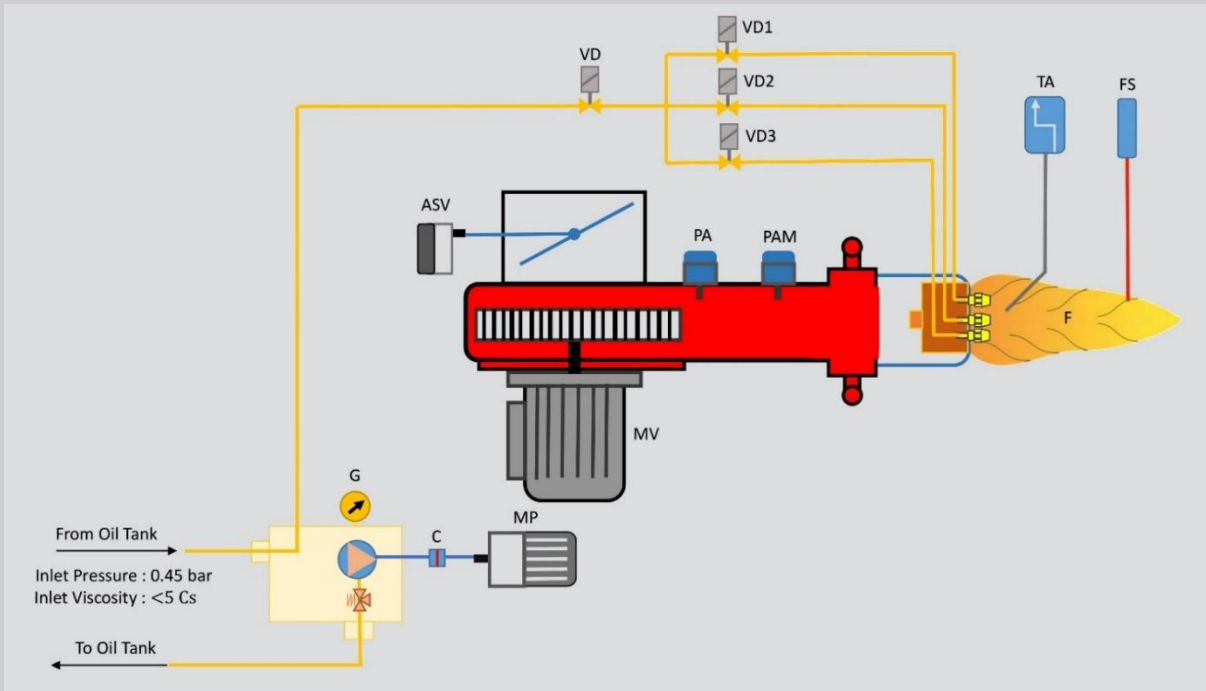

MV: Fan motor
 MP: Pump motor
 FS: Flame sensor
 VD: Light oil safety valve

VD1: Light oil delivery valve Stage 1
 VD2: Light oil delivery valve Stage 2
 VD2: Light oil delivery valve Stage
 TA: ignition transformer

C: Coupling
 G: Gauge
 F: Gas or oil flame
 ASV: Air damper servomotor
 PA: Air pressure switch

Emission

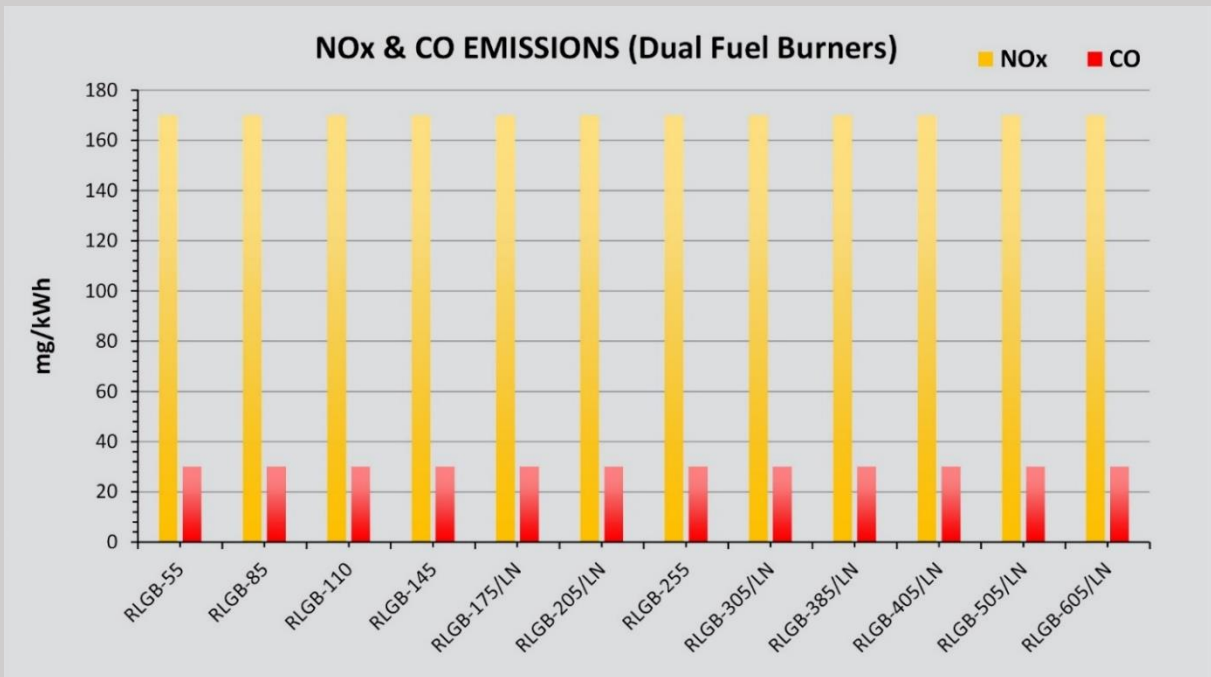
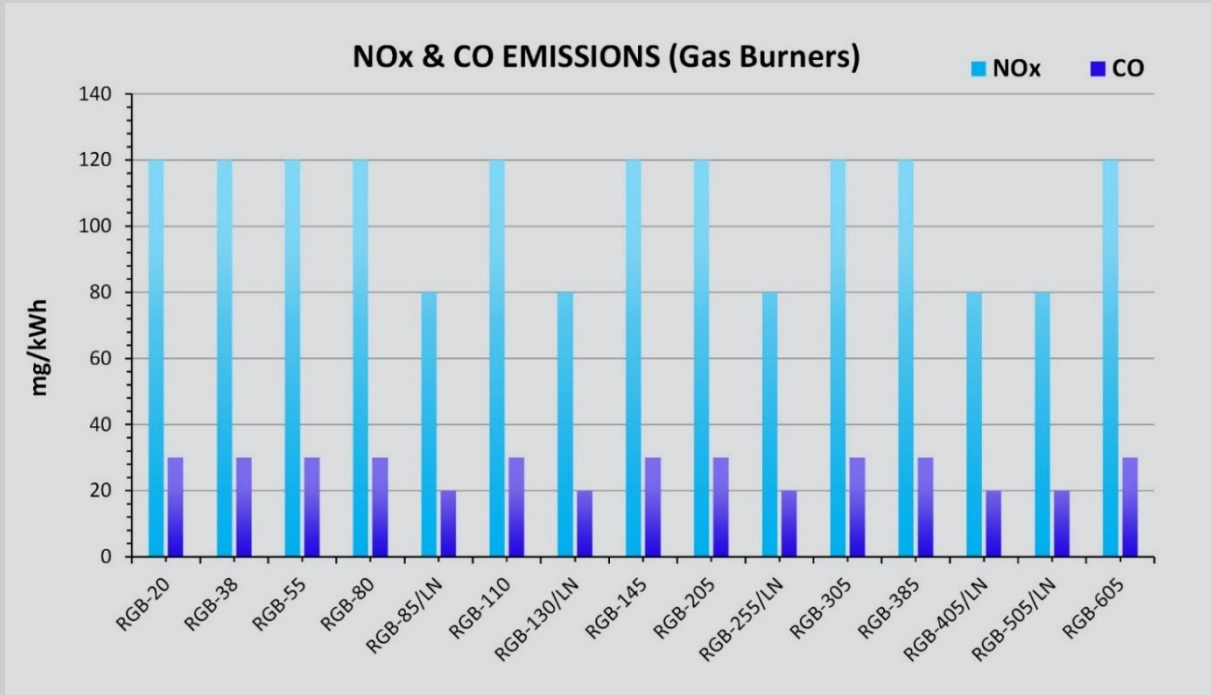

raadman Staging (mono-block) Burners cover a firing range of 160 up to 6,200 kW generally. They can be used wherever heat is needed in heating residences or hospitals, schools or offices, in industry or trade, on board ships and for mobile plant. They are suitable for all commonly available gas and oil types and are notable for their superior reliability, longevity, great economy and ease of manganese.



PACKMAN

Industrial Group

Web: www.packmangroup.com

Web: www.raadmanburner.com



[packmangroup.co](https://www.instagram.com/packmangroup.co)

[raadman.burner](https://www.instagram.com/raadman.burner)

Head office: 79 No. 10 Street, Bokharest Ave. Tehran, Iran.

Tel: (+98) 021 42 362, (+98) 021 88739075-9, 88731618

Fax: (+98) 021 88737131

Burner Factory: No.5, 102 ave. Montazeriye Industrial town, Vilashahr, Isfahan, Iran

Technical and sale consultant:

Tel: (+98) 031 4229 0483

Mobile: (+98) 913 460 5664

Email: vah.azizi@gmail.com

