

1 2 3 4 5 6 7 8 9 10

11 12

A
B
C
D
E
F
G
H
I
J

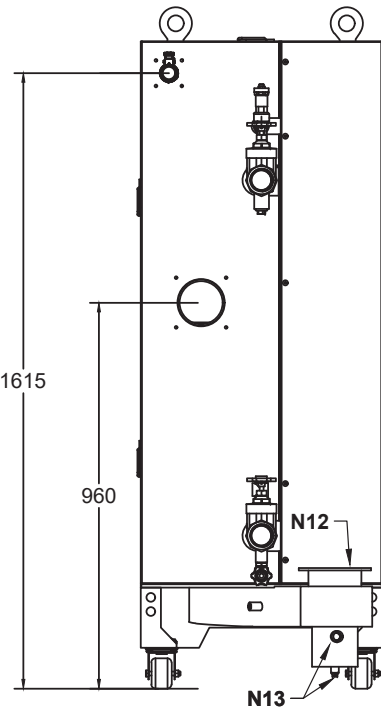
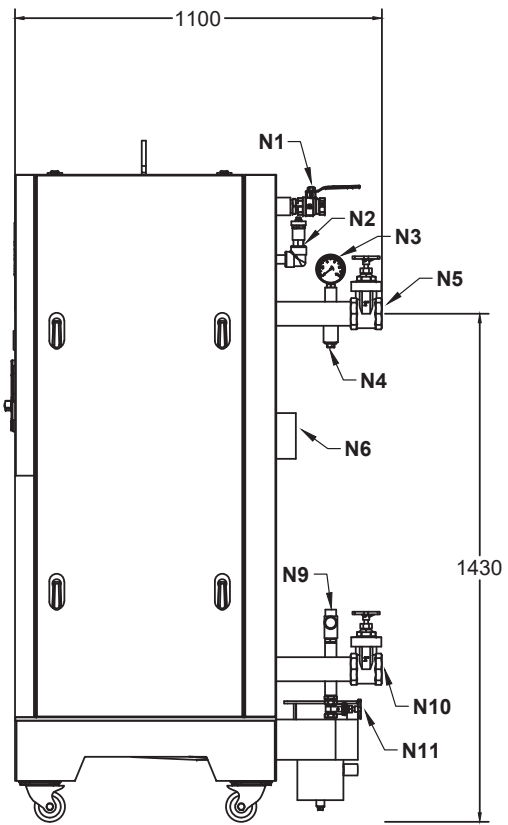
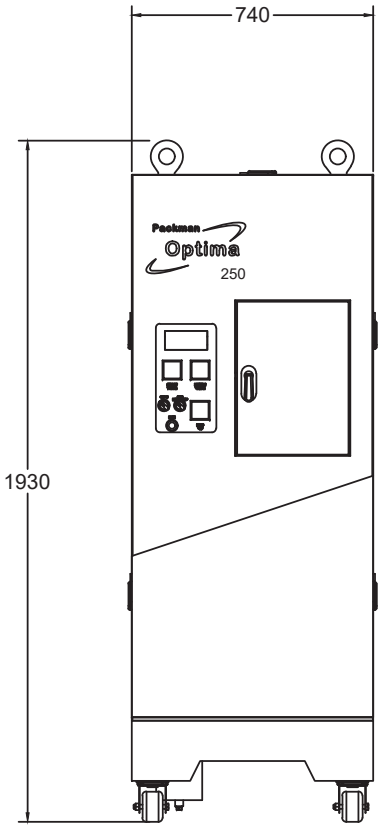

TECHNICAL DATA		
DESIGN		
CAPACITY (kcal/hr)	215,000	
WORKING PRESSURE (bar)	10	
CORROSION ALLOWANCE	0	
MATERIAL		
FURNACE	316 L Stainless Steel	
TUBE SHEETS	316 L Stainless Steel	
FIRE TUBES	316 L Stainless Steel	
INSPECTION		
PENETRATION TEST	YES	
HYDROSTATIC TEST	YES	
CONNECTIONS SIZE		
GAS VALVE	N 1	1 1/2"
AIR VENT	N 2	1/2"
MANOMETER	N 3	1/2"
SPARE	N 4	3/4"
OUTLET	N 5	2 1/2"
AIR INTAKE	N 6	6"
RELIEF VALVE	N 9	1/2"
INLET	N 10	2 1/2"
DRAIN	N 11	1/2"
STACK I.D	N 12	6"
CONDENSATE DRAIN	N 13	1/2"

GENERAL NOTE

- ALL DIMENSIONS & ELEVATIONS ARE IN mm.
- THE MAP CONTAINS THE CONSTRUCTION TOLERANCES
- THE MAP PROVIDED IS NOT SCALED. SCALED MAP IS PROVIDED UPON REQUEST.

TITLE:
CONDENSING BOILER (OPTIMA) DIMENSION DRAWING

DRAFTED	CHECKED	APPROVED	CONFIRMED	REV.	SCALE
				R02	NTS

VENDOR:

PACKMAN
Industrial Group

