

1 2 3 4 5 6 7 8 9 10

11 12

A
B
C
D
E
F
G
H
I
J

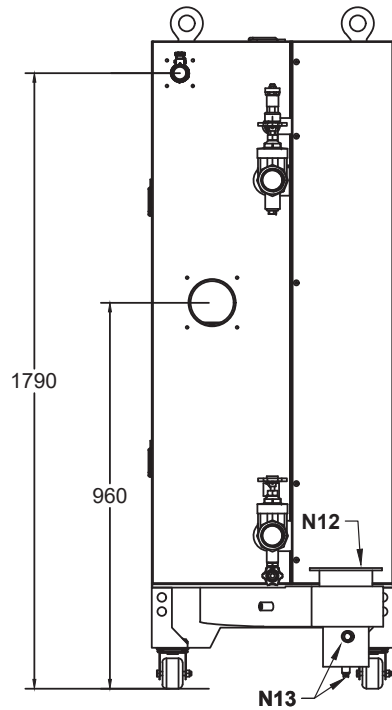
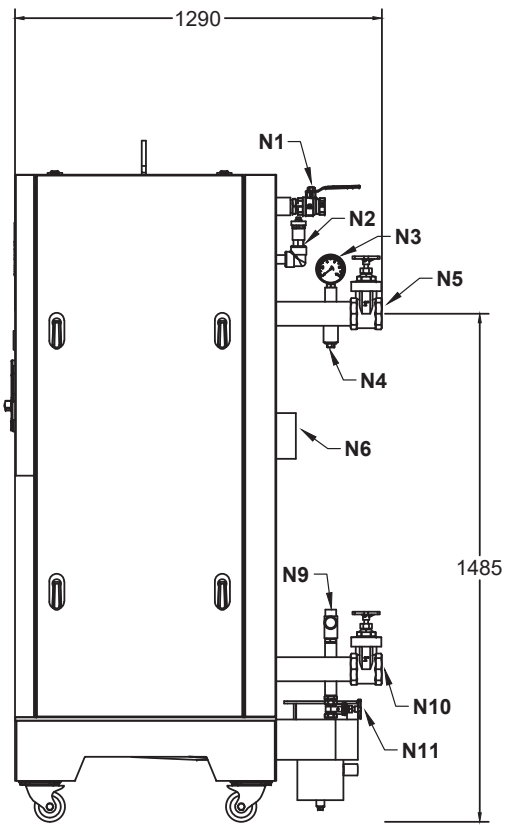
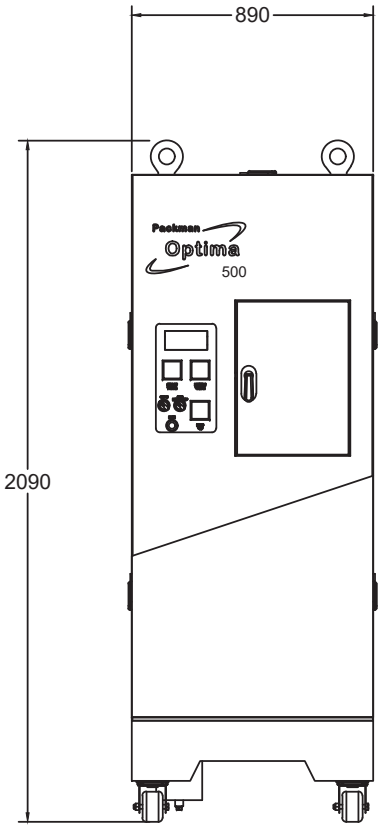

TECHNICAL DATA	
DESIGN	
CAPACITY (kcal/hr)	430,000
WORKING PRESSURE (bar)	10
CORROSION ALLOWANCE	0

MATERIAL	
FURNACE	316 L Stainless Steel
TUBE SHEETS	316 L Stainless Steel
FIRE TUBES	316 L Stainless Steel

INSPECTION	
PENETRATION TEST	YES
HYDROSTATIC TEST	YES

CONNECTIONS SIZE		
GAS VALVE	N 1	1½"
AIR VENT	N 2	½"
MANOMETER	N 3	½"
SPARE	N 4	1"
OUTLET	N 5	3"
AIR INTAKE	N 6	8"
RELIEF VALVE	N 9	½"
INLET	N 10	3"
DRAIN	N 11	½"
STACK I.D	N 12	8"
CONDENSATE DRAIN	N 13	½"

GENERAL NOTE

- ALL DIMENSIONS & ELEVATIONS ARE IN mm.
- THE MAP CONTAINS THE CONSTRUCTION TOLERANCES
- THE MAP PROVIDED IS NOT SCALED. SCALED MAP IS PROVIDED UPON REQUEST.

TITLE:
CONDENSING BOILER (OPTIMA) DIMENSION DRAWING

DRAFTED	CHECKED	APPROVED	CONFIRMED	REV.	SCALE
				R02	NTS

VENDOR:



PACKMAN
Industrial Group

