

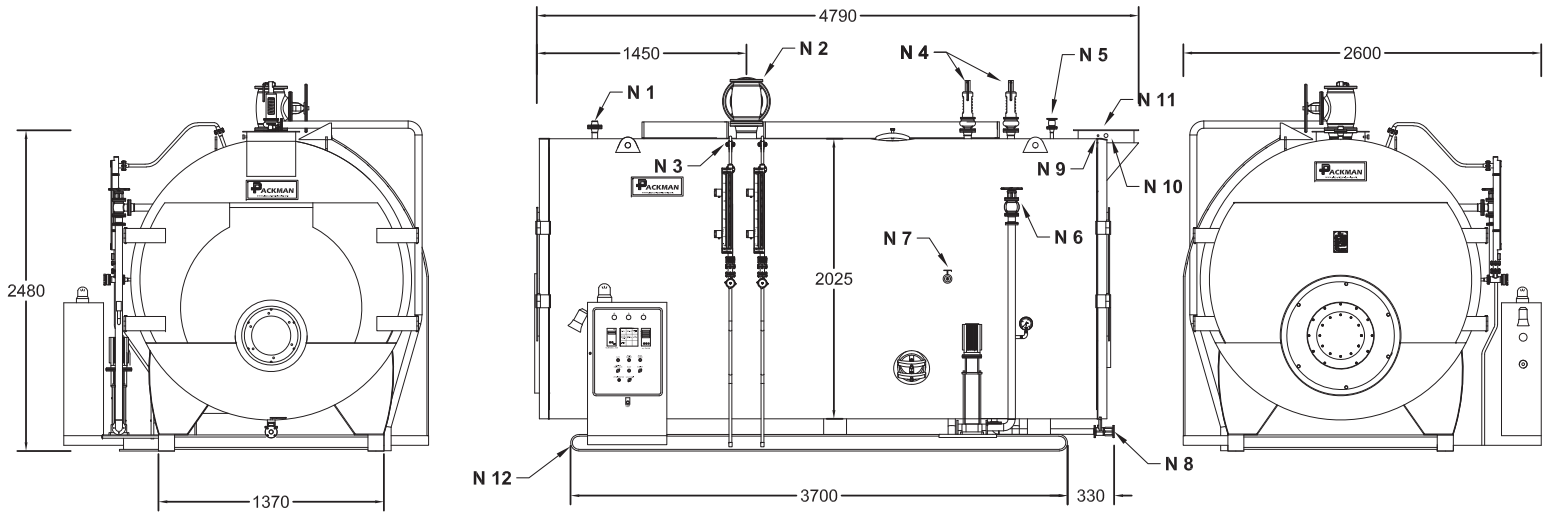

1 2 3 4 5 6 7 8 9 10

A  
B  
C  
D  
E  
F  
G  
H  
I  
J



11 12

TECHNICAL DATA					
DESIGN					
DESIGN STANDARD	BS/EN12953				
CAPACITY (kg/hr)	3,000				
WORKING PRESSURE (bar)	10				
CORROSION ALLOWANCE	0.75 (mm)				
MATERIAL					
SHELL & FURNACE	17Mn-4 (DIN 17155)				
TUBE SHEETS	17Mn-4 (DIN 17155)				
FIRE TUBES	St 35.8 (DIN 17175)				
FLANGES	FORGED STEEL ASME B,16.5-150				
INSPECTION					
PENETRATION TEST	YES				
ULTRASONIC TEST	YES				
HYDROSTATIC TEST	YES				
CONNECTIONS SIZE					
INSTR. MANIFOLD	N 1	2"			
STEAM OUTLET	N 2	4"			
LEVEL CONTROLLER	N 3	1"			
SAFETY VALVE	N 4	1½"			
VENT	N 5	1"			
FEED WATER INLET	N 6	2"			
SAMPLING	N 7	½"			
DRAIN	N 8	1½"			
TEMPERATURE SENSOR	N 9	½"			
THERMO METER	N 10	½"			
STACK	N 11	16"			
I-BEAM SIZE (IPN)	N 12	160 II			
GENERAL NOTE					
1- ALL DIMENSIONS & ELEVATIONS ARE IN mm.					
2-THE MAP CONTAINS THE CONSTRUCTION TOLERANCES					
3-THE MAP PROVIDED IS NOT SCALED. SCALED MAP IS PROVIDED UPON REQUEST.					
TITLE: THREE PASS STEAM BOILER DIMENSION DRAWING					
DRAFTED	CHECKED	APPROVED	CONFIRMED	REV.	SCALE
				R01	NTS
VENDOR:					
 <b>PACKMAN</b> Industrial Group					
