

1 2 3 4 5 6 7 8 9 10 11 12

A

B

C

D

E

F

G

H

I

J

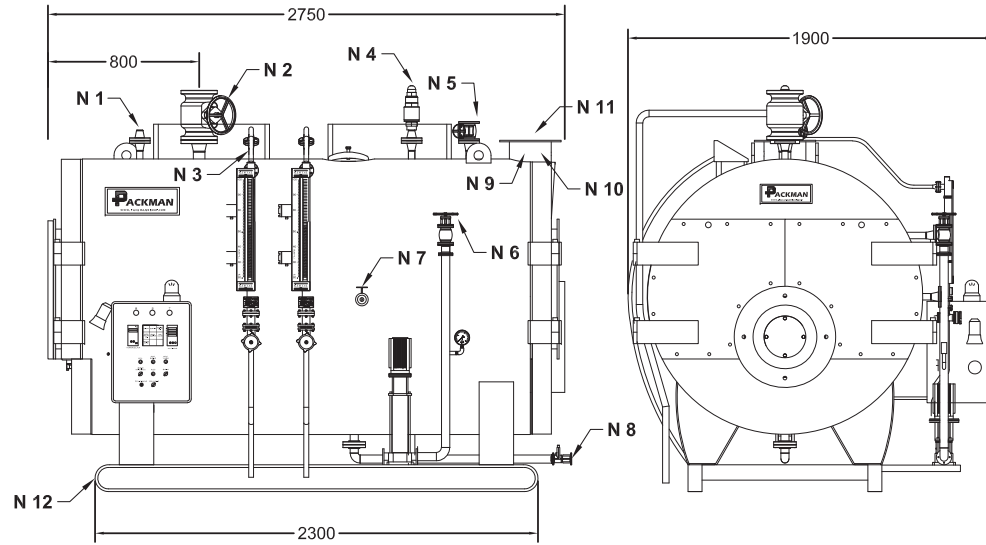
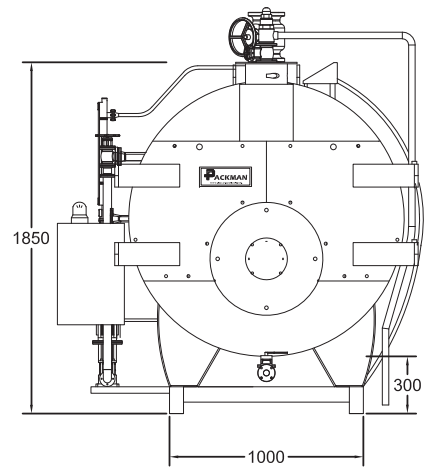

TECHNICAL DATA

DESIGN

DESIGN STANDARD	BS/EN12953
CAPACITY (kg/hr)	500
WORKING PRESSURE (bar)	10
CORROSION ALLOWANCE	0.75 (mm)

MATERIAL

SHELL & FURNACE	17Mn-4 (DIN 17155)
TUBE SHEETS	17Mn-4 (DIN 17155)
FIRE TUBES	St 35.8 (DIN 17175)
FLANGES	FORGED STEEL ASME B.16.5-150

INSPECTION

PENETRATION TEST	YES
ULTRASONIC TEST	YES
HYDROSTATIC TEST	YES

CONNECTIONS SIZE

INSTR. MANIFOLD	N 1	1 1/2"
STEAM OUTLET	N 2	2"
LEVEL CONTROLLER	N 3	1"
SAFETY VALVE	N 4	1"
VENT	N 5	1"
FEED WATER INLET	N 6	1"
SAMPLING	N 7	1/2"
DRAIN	N 8	1 1/2"
TEMPERATURE SENSOR	N 9	1/2"
THERMO METER	N 10	1/2"
STACK	N 11	8"
I-BEAM SIZE (IPN)	N 12	140

GENERAL NOTE

- 1- ALL DIMENSIONS & ELEVATIONS ARE IN mm.
- 2-THE MAP CONTAINS THE CONSTRUCTION TOLERANCES
- 3-THE MAP PROVIDED IS NOT SCALED. SCALED MAP IS PROVIDED UPON REQUEST.

TITLE:
THREE PASS STEAM BOILER DIMENSION DRAWING

DRAFTED	CHECKED	APPROVED	CONFIRMED	REV.	SCALE
				R01	NTS

VENDOR:



PACKMAN
Industrial Group

0 1 2 3 4 5 6 7 8 9 10