

1 2 3 4 5 6 7 8 9 10

A
B
C
D
E
F
G
H
I
J

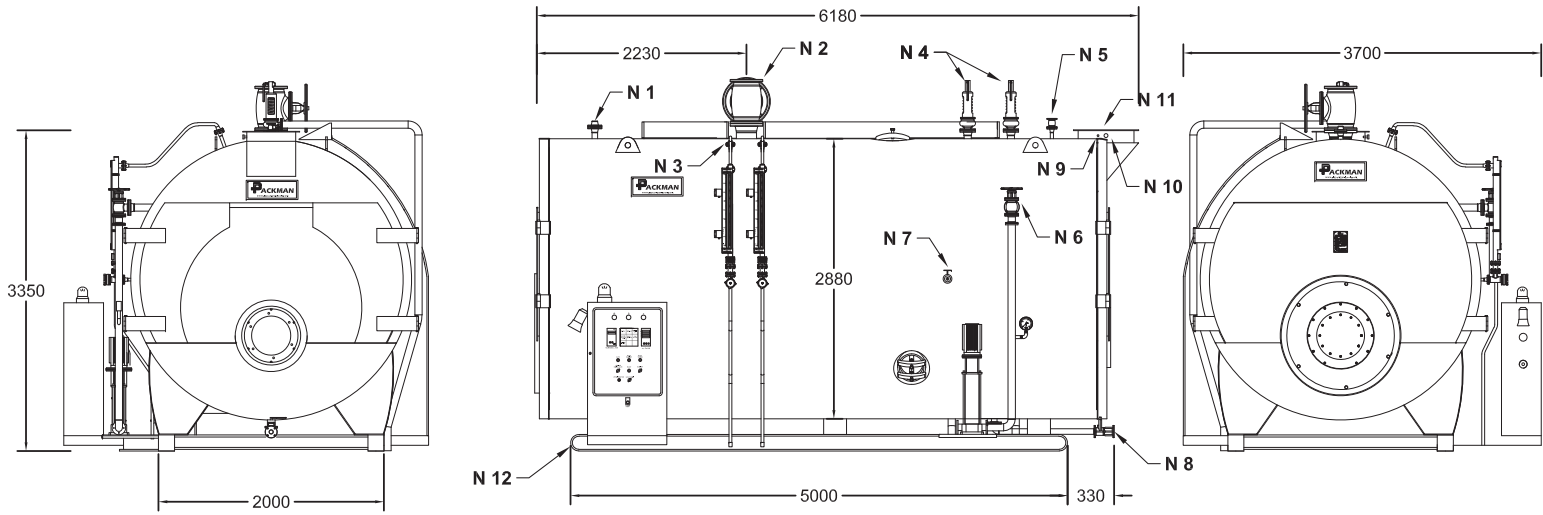

11 12
TECHNICAL DATA

DESIGN	
DESIGN STANDARD	BS/EN12953
CAPACITY (kg/hr)	11,600
WORKING PRESSURE (bar)	10
CORROSION ALLOWANCE	0.75 (mm)

MATERIAL	
SHELL & FURNACE	17Mn-4 (DIN 17155)
TUBE SHEETS	17Mn-4 (DIN 17155)
FIRE TUBES	St 35.8 (DIN 17175)
FLANGES	FORGED STEEL ASME B,16.5-150

INSPECTION	
PENETRATION TEST	YES
ULTRASONIC TEST	YES
HYDROSTATIC TEST	YES

CONNECTIONS SIZE		
INSTR. MANIFOLD	N 1	2"
STEAM OUTLET	N 2	8"
LEVEL CONTROLLER	N 3	1"
SAFETY VALVE	N 4	2½"
VENT	N 5	1"
FEED WATER INLET	N 6	2½"
SAMPLING	N 7	½"
DRAIN	N 8	2"
TEMPERATURE SENSOR	N 9	½"
THERMO METER	N 10	½"
STACK	N 11	24"
I-BEAM SIZE (IPN)	N 12	180 II

GENERAL NOTE

1- ALL DIMENSIONS & ELEVATIONS ARE IN mm.
 2-THE MAP CONTAINS THE CONSTRUCTION TOLERANCES
 3-THE MAP PROVIDED IS NOT SCALED. SCALED MAP IS PROVIDED UPON REQUEST.

TITLE:
THREE PASS STEAM BOILER DIMENSION DRAWING

DRAFTED	CHECKED	APPROVED	CONFIRMED	REV.	SCALE
				R01	NTS

VENDOR:



PACKMAN
Industrial Group